



Principles of Leak Detection

Prof. Dr.-Ing. Gerhard Geiger

KROHNE

▶ *achieve more*

Preface

Pipeline networks are the most economic and safest method of transport for mineral oil, gases and other fluid products. Pipelines have to meet high demands for safety, reliability and efficiency. Most pipelines, regardless of what they transport, are designed with a lifespan of around 25 years. When they do begin to fail, they do so slowly beginning with leaks at poor construction joints, corrosion points and small structural material cracks, and gradually progress to a catastrophic ending. But there are also other reasons for leak disasters such as accidents, terrorism, sabotage and theft.

The primary purpose of leak detection systems (LDS Systems) is to assist pipeline controllers in detecting and localizing leaks. LDS Systems provide an alarm, and display other related data to the pipeline controllers in order to aid in decision-making. Pipeline leak detection systems are also beneficial because they can enhance productivity and system reliability thanks to reduced downtime and reduced inspection time. LDS Systems are therefore an important aspect of pipeline technology.

This report presents an overview about the most commonly used principles for leak detection (and leak localization). The main focus is on "internal" LDS systems, which utilize field instrumentation (for example flow, pressure and fluid temperature sensors) to monitor internal pipeline parameters. A significant part of this report is dedicated to model-based leak detection which is usually called Real-Time Transient Model (RTTM) based LDS, and in particular Extended RTTM based LDS which combines computer based modeling and simulation techniques with statistical leak classification (or leak signature analysis). In this, the second edition, chapters about instrumentation issues, data communication (SCADA) and leak monitoring in shut-in conditions have been added. Furthermore, enhancements of PipePatrol Statistical Line Balance (SLB) have led to substantial revisions of the related chapter.

A comparison of all presented principles and methods is also included in the text, which may help the reader to select a leak detection principle that is most suitable for a particular application. Characteristics are listed on an informative basis, and while they are to some extent subjective by nature every effort has been made in this document to present objective facts.

Finally, the reader will find a comprehensive list of definitions that are relevant in the field of leak detection at the end of this report.

*Gerhard Geiger, Reken, Germany
geiger_g@t-online.de*

Contents

Preface	i
Contents	ii
List of Figures	iv
List of Tables	iv
Symbols and Units	v
1 Introduction	1
2 Regulatory Framework	3
2.1 TRFL (Germany)	3
2.2 API RP 1130 (USA)	4
3 Instrumentation Issues	5
3.1 Performance Measures	5
3.2 Flow meters [ADEC]	6
4 Supervisory Control and Data Acquisition (SCADA)	7
4.1 Components of a SCADA System	7
4.2 Data Acquisition	8
4.3 Data Communication Equipment (DCE)	8
5 Pressure/Flow Monitoring	10
5.1 Pressure Monitoring	10
5.2 Flow Monitoring	10
5.3 Summary	10
6 Rarefaction Wave Method	12
6.1 Summary	12
7 Balancing Methods	14
7.1 Some Comments on Definitions	14
7.2 Uncompensated Mass Balance	15
7.3 Compensated Mass Balance	16
7.4 Use of Volumetric Flow Meters	17
7.5 Balancing at Standard Conditions	17
7.6 Volume Balancing	17
7.7 Summary	18
8 Statistical Leak Detection Systems	20
8.1 Hypothesis Testing	20
8.2 Signature Analysis	21
8.3 Summary	21
9 Leak Monitoring during Shut-In Conditions	23
9.1 PT – Pressure-Temperature Method	23

9.2	DP – Differential Pressure Method	24
9.3	Summary	24
10	Leak Localization	26
10.1	Gradient Intersection Method	26
10.2	Time-of-Flight Method	26
11	RTTM – Real Time Transient Model	27
11.1	Compensation Approach	29
11.2	Flow Residual Approach	30
11.3	Pressure Residual Approach	31
12	PipePatrol Statistical Line Balance (SLB)	32
12.1	Pipeline Inventory Compensation	32
12.2	Statistical Leak Classification	33
12.3	Summary	33
13	PipePatrol Extended Real-Time Transient Model (E-RTTM)	35
13.1	Pipeline Observer	35
13.2	Leak Signature Analysis	35
13.3	Leak Location	35
13.4	PipePatrol E-RTTM/PC – Leak Monitoring in Pumping Conditions	36
13.5	PipePatrol E-RTTM/SC – Leak Monitoring in Shut-in Conditions	39
13.6	Summary	42
14	Comparison of All Methods	45
14.1	Functionality and Instrumentation	45
14.2	Field of Application	45
14.3	Performance Parameters	45
A	Bibliography	47
B	Definitions	48
	About the Author	61

List of Figures

Figure 1: SCADA system for an example application	7
Figure 2: Conditional probability density functions (PDF)	20
Figure 3: Leak detection during shut-in by PT method	23
Figure 4: Leak detection during shut-in by DP method	24
Figure 5: Leak location by gradient intersection method	26
Figure 6: RTTM to calculate local profiles; model using pressure (and temperature) readings	27
Figure 7: RTTM to calculate local profiles; model using flow (and temperature) readings	28
Figure 8: Compensated mass balance with RTTM based compensation	29
Figure 9: Flow residual approach	30
Figure 10: Pressure residual approach	31
Figure 11: PipePatrol Statistical Line Balance (SLB)	32
Figure 12: PipePatrol E-RTTM/PC - head station monitoring	36
Figure 13: PipePatrol E-RTTM/PC - substations monitoring	37
Figure 14: PipePatrol E-RTTM/PC - sectional monitoring, substations fully instrumented	38
Figure 15: PipePatrol E-RTTM/PC - sectional monitoring, substations without flow measurement	39
Figure 16: PipePatrol E-RTTM/SC - head station monitoring	40
Figure 17: PipePatrol E-RTTM/SC - substations monitoring	41

List of Tables

Table 1: Symbols and units – Part 1	v
Table 2: Symbols and units – Part 2	vi
Table 3: Functionality and instrumentation of pressure and flow monitoring	10
Table 4: Fields of application of pressure and flow monitoring	10
Table 5: Performance parameters of pressure and flow monitoring	11
Table 6: Functionality and instrumentation of rarefaction wave method	12
Table 7: Fields of application for rarefaction wave method	12
Table 8: Performance parameters of rarefaction wave method	12
Table 9: Functionality and instrumentation for balancing methods	18
Table 10: Fields of application for balancing methods	19
Table 11: Performance parameters for balancing methods	19
Table 12: Functionality and instrumentation for statistical LDS	22
Table 13: Fields of application for statistical LDS	22
Table 14: Performance parameters for statistical LDS	22
Table 15: Functionality and instrumentation for leak monitoring during shut-in conditions	24
Table 16: Fields of application for leak monitoring during shut-in conditions	25
Table 17: Performance parameters for leak monitoring during shut-in conditions	25
Table 18: Functionality and instrumentation for PipePatrol SLB	33
Table 19: Fields of application for PipePatrol SLB	33
Table 20: Performance parameters for PipePatrol SLB	34
Table 21: Functionality and instrumentation of PipePatrol E-RTTM	42
Table 22: Fields of application of PipePatrol E-RTTM	43
Table 23: Performance parameters of PipePatrol E-RTTM	43
Table 24: Comparison of all methods	46

Symbols and Units

Symbol	Meaning	SI-Unit
c	Speed of sound	m/s
e	Relative measurement error	
E	Absolute measurement error	
L	Length of pipeline	m
M	Mass in general	kg
M_{Leak}	Spilled leak mass	kg
M_{Pipe}	Mass stored in pipeline	kg
\dot{M}	Mass flow in general	kg/s
\dot{M}_I	Mass flow at inlet	kg/s
\dot{M}_{Leak}	Leak flow	kg/s
\dot{M}_O	Mass flow at outlet	kg/s
p, P	Pressure in general	Pa
P	Probability in general	
P_{FA}	Probability of false alarm	
P_{MA}	Probability of missed alarm	
Q	Flow in general	$kg/s, m^3/s$
Q_I	Flow at inlet	$kg/s, m^3/s$
Q_O	Flow at outlet	$kg/s, m^3/s$
s	One-dimensional coordinate along the pipeline	m
s_{Leak}	Position of leak	m
t	Time	s
t_{down}	Downstream arrival time of rarefaction wave caused by a leak	s
t_{up}	Upstream arrival time of rarefaction wave caused by a leak	s
T	Temperature in general	K
T_G	Temperature of ground	K
V	Volume in general	m^3
V_{Pipe}	Volume of the pipeline	m^3
\dot{V}	Volume flow in general	m^3/s
\dot{V}_I	Volume flow at inlet	m^3/s
\dot{V}_s	Volume flow at standard conditions	sm^3/s
\dot{V}_O	Volume flow at outlet	m^3/s
x	Actual measurement of any physical variable	
x	Flow residual at inlet	kg/s
x_{ref}	Reference value for calculation of relative measurement error	
x_{true}	True value of any physical variable	
y	Flow residual at outlet	kg/s
z	Pressure residual in general	Pa

Table 1: Symbols and units – Part 1

Symbol	Meaning	SI-Unit
γ	Leak alarm threshold for mass balance	kg/s
γ_s	Leak alarm threshold for standard volume balance	sm^3/s
γ'	Leak alarm threshold for volume balance	m^3/s
ΔM_I	Mass entering pipeline at inlet integrated over some time Δt	kg
ΔM_O	Mass leaving pipeline at outlet integrated over some time Δt	kg
ΔM_{Pipe}	Change of mass inventory over some time Δt	kg
Δt	Time difference in general	s
Δt	Time delay evaluated by time-of-flight method	s
ΔV_I	Volume entering pipeline at inlet integrated over some time Δt	m^3
ΔV_O	Volume leaving pipeline at outlet integrated over some time Δt	m^3
ε	Relative resolution of data acquisition	
E	Absolute resolution of data acquisition	
ϑ	Temperature in general	$^{\circ}C$
Λ	Probability ratio	
μ	Mean of a Gaussian distribution	
ρ	Density of the fluid	kg/m^3
$\bar{\rho}$	Mean density of the fluid along the pipeline	kg/m^3
σ	Standard deviation of the Gaussian distribution	

Table 2: Symbols and units – Part 2

1 Introduction

Modern leak detection systems such as the PipePatrol family from KROHNE Oil and Gas monitor pipelines continuously, by logically testing whether a leak has occurred or not (leak detection). In case of a leak they also calculate the leak flow and the leak position (leak localization).

Some countries formally regulate pipeline safety, for example the German rules are laid down in “Technische Regeln für Rohrfernleitungsanlagen” [TRFL]. Other countries provide guidelines and recommended practices, for example leak detection is specifically addressed by [API RP 1130] in the USA. [API RP 1130] defines the following important requirements of an LDS¹:

Sensitivity: An LDS should ensure that the loss of fluid as a result of a leak is as small as possible. This places two requirements on the system: it should detect *small leaks*, and it should detect them *quickly*. PipePatrol Extended Real-Time Transient Model E-RTTM (Chapter 13) is able to detect leakage below 1% of nominal flow rate within less than a minute. PipePatrol Statistical Line Balance (SLB, Chapter 12) may alternatively be used if demand for sensitivity is reduced and/or leak localization is not required.

Reliability: The user must be able to trust the LDS. This means that it should correctly alarm any real leak, but it is equally important that it does not generate false alarms. PipePatrol E-RTTM therefore uses *leak signature analysis* based on well-known and proven statistical procedures.

Accuracy: The LDS should report the leak location (and leak flow) accurately. This enables targeted actions for repair and re-establishing safety.

Robustness: The LDS should continue to operate in non-ideal circumstances. For example, in case of a transducer failure the system must detect the failure and continue to operate (possibly with necessary compromises such as reduced sensitivity). Taking PipePatrol E-RTTM as an example, this E-RTTM based LDS optionally uses the much simpler PipePatrol Statistical Line Balance (SLB) as a backup if pressure or temperature sensors fail.

These performance measures can be found in [API RP 1130]. But there are further requirements:

Universal Applicability: A modern LDS is expected to be universally applicable. For example, PipePatrol can be used with equal success on liquid or gas pipelines, and operates effectively on single-product and multi-product pipelines with or without separation pigs. Drag reducing agent (DRA) creates some challenges, but no insurmountable problems.

Wide operating range: Leak detection is important throughout the whole operating envelope, including unsteady, or “transient”, states. It should continue to function in highly transient states such as start-up and shutdown and moderately transient states such as flow adjustment as well as the steady state. Some LDSs also provide a model that works under shut-in conditions such as PipePatrol E-RTTM, see Chapter 13.

According to [API RP 1130], LDSs are divided into two groups:

- *External systems* using dedicated measurement equipment, such as a sensor cables
- *Internal systems* using existing measurement sensors for flow, pressure and so on

External systems provide excellent performance but in many cases cannot operate continuously. Investment and operational costs are usually very high because they need dedicated measurement equipment such as sensor cables that must be laid along the pipeline. For that reason, external systems will only be used in critical applications, for example when pipelines cross nature reserves.

Internal systems usually run continuously. Sensitivity is generally lower, but so are investment and operational costs. For this reason, internal systems are very common and are required by law for most pipelines in countries such as Germany. The focus of this survey therefore is on internal systems.

Internal LDSs use existing instrumentation e.g. for flow, pressure and temperature. Instrumentation issues and data communication (SCADA) topics are therefore very important and are discussed in Chapters 3 and 4, respectively.

This survey describes the principles of internal LDS and leak location as follows:

¹These definitions formerly had been part of [API 1155], which had been withdrawn by API. Valuable definitions and discussions are now included into annex C from [API RP 1130].

- Chapter 5: Pressure/Flow Monitoring
- Chapter 6: Rarefaction Wave Method
- Chapter 7: Balancing Methods
- Chapter 8: Statistical Leak Detection Systems
- Chapter 9: Leak Monitoring during Shut-In Conditions
- Chapter 10: Leak Localization

These methods and principles have been well-known for decades. Great improvements in the field of computer hardware and software make it possible to simulate sophisticated transient models of the pipeline *in real-time*. Chapter 11 therefore describes in detail principles of using Real-Time Transient Models (RTTMs) for leak monitoring.

Chapter 12 describes PipePatrol Statistical Line Balance (SLB), which combines the mass balance with statistical methods and optionally RTTM technology. Chapter 13 describes PipePatrol Extended Real-Time Transient Model E-RTTM, the premium leak detection solution of KROHNE Oil & Gas.

Chapter 14 provides a comparison of available leak detection methods which may help the reader to select a LDS principle which is most suitable for a particular application. Listed information is provided on an informative basis and subjective by nature. Last but not least the interested reader will find within Appendix B a comprehensive list of definitions which are relevant in the field of leak monitoring.

2 Regulatory Framework

2.1 TRFL (Germany)

German TRFL stands for „Technische Regeln für Rohrfernleitungsanlagen“ [TRFL], which was firstly published in 2003 and revised in 2010. [TRFL] applies to most German pipelines transporting liquids or gases. It demands:

- a) Two autonomous, continuously operating systems that can detect leaks in *steady state conditions*. These two systems must rely on different physical variables. (For gas and brine pipelines under well-defined operating conditions, only one system may be necessary.)
- b) One of these systems, or a third one, must be able to detect leaks *in transient conditions*.
- c) One system to detect leaks in paused flow conditions.
- d) One system or procedure to detect gradual leaks.
- e) One system or procedure to detect the leak position.

2.1.1 Installations According to TRFL a) and b)

[TRFL] requires two autonomous, continuously operating LDSs that can detect leaks in the steady state. Either of these systems, or both, or a third one, must be able to detect leaks in transient conditions.

Special attention should be paid to the difference between the *steady state* and the *transient state*. Steady state conditions exist when all relevant physical variables such as flow, pressure, temperature and density are sufficiently constant along the pipeline to ensure that no wave effects can be observed. Transient conditions exist when the physical variables change significantly with time, so wave effects are present. Reasons for these changes include product compressibility and pipe elasticity, together with special operational conditions such as:

- Starting and stopping pumps or compressors during start-up and shutdown
- Valve operation anywhere before, along or beyond the monitored pipeline segment
- Flow or pressure control actions
- Changes of target throughput
- Special cases such as cavitation

Experience shows that gas pipelines are usually in a (moderately) transient state as a result of the high gas compressibility. Liquid pipelines are often operated in a steady state, but on close examination transient effects can also frequently be observed.

PipePatrol Extended Real-Time Transient Model (E-RTTM) from KROHNE Oil & Gas offers a state-of-the-art leak detection system capable of operating in both steady state and transient conditions; for details refer to Chapter 13.

2.1.2 Installations According to TRFL c)

[TRFL] requires that each pipeline has one system to detect leaks in paused flow conditions, see Chapter 9. In this context, paused flow just means "flow equal or close to zero"; nothing is said about how this will be achieved. If the flow is blocked by valves locking pressure with the pipeline segment, it is said to be in the *shut-in condition*. PipePatrol E-RTTM Chapter 13 uses a model-based *pressure-temperature method (PT method)*, which can be applied to pipelines in shut-in conditions.

2.1.3 Installations According to TRFL d)

Gradual leaks (for example caused by corrosion) have two important characteristics: leak flow usually is (very) small, and it develops slowly. Installations according to TRFL a) are not well-suited to detecting this type of leak, so [TRFL] requires a dedicated LDS for this purpose.

An external LDS can be used, but this is very expensive. Internal LDS techniques including the pressure-temperature method Chapter described in Chapter 9.1 and differential pressure method described in Chapter 9.2 can also be used to detect gradual leaks.

If adequate, leak tight valves are present, the PipePatrol E-RTTM/SC model-based pressure-temperature method can also be applied, see Chapter 13.5.

2.1.4 Installations According to TRFL e)

The TRFL additionally requires a system (or other procedure) to locate leaks rapidly, enabling targeted actions for repair and re-establishing safety. This function can be integrated into one of the systems installed to comply with section a) – for example, PipePatrol E-RTTM, Chapter 13. Details of leak localization are described in Chapter 10.

2.2 API RP 1130 (USA)

The first edition of API (American Petroleum Institute) Recommended Practice (RP) 1130 “Computational Pipeline Monitoring for Liquid Pipelines” was published 2007 [API RP 1130]. API RP 1130 does not directly impose legal requirements on pipeline operators in the same way as TRFL, but:

- Gives a technical overview of leak detection technology
- Describes infrastructure support for CPM²
- Discusses CPM operation, maintenance and testing

It provides the necessary technical information for conscientious operators and pipeline controllers to manage their pipelines safely.

[API RP 1130] covers liquid pipelines only. LDSs are divided into two groups:

- *External systems* using dedicated measurement equipment, such as a sensor cables.
- *Internal systems* using existing measurement sensors for flow, pressure etc. All LDSs introduced in this survey are part of this group.

[API RP 1130] also defines criteria (or measures) for comparing LDSs from different manufacturers³:

- *Sensitivity*: The sensitivity is a composite measure of the size of a leak that a system is capable of detecting, and the time required for the system to issue an alarm in the event that a leak of that size should occur. Volume or mass lost between the occurrence of a leak and its detection is a more objective measure of performance than the smallest detectable leak flow. PipePatrol E-RTTM typically detects leakage below 1% of nominal flow rate in less than one minute, resulting in a leak volume that is typically less than 50 liters.
- *Reliability*: Reliability is a measure of the ability of a leak detection system to render accurate decisions about the possible existence of a leak on the pipeline, while operating within an envelope established by the leak detection system design. It follows that reliability is directly related to the probability of detecting a leak, given that a leak does in fact exist, and the probability of incorrectly declaring a leak, given that no leak has occurred.
- *Accuracy*: Accuracy covers estimation of leak parameters such as leak flow rate, total volume lost, type of fluid lost, and leak location within the pipeline network. These leak parameter estimates should be as accurate as possible.
- *Robustness*: Robustness is a measure of the leak detection system’s ability to continue to function and provide useful information even under changing conditions of pipeline operation, or in conditions where data is lost or suspect. A system is considered to be robust if it continues to function under such non-ideal conditions.

² CPM = Computational Pipeline Monitoring. This is a software-based LDS.

³ These criteria were originally published in [API 1155] which is been withdrawn by API. Useful definitions and discussions have been moved into an Annex of [API RP 1130].

3 Instrumentation Issues

For the internal leak detection principles presented in the next chapters, instrumentation includes:

- Flow meters
- Pressure sensors
- Temperature sensors

[API 1149] addresses the effect of measurement uncertainty on leak detection system sensitivity. It considers steady state flow in liquid pipelines using pipe characteristics to establish the environment in which the measurements are made. It then considers measurement accuracy and uncertainty from the instrument vendors in order to determine theoretical leak detection sensitivity based on measurement quality. The result is a theoretical limit to leak detection sensitivity based on instrument accuracy and pipeline characteristics.

3.1 Performance Measures

In general, applying a specific LDS principle implies specific performance requirements for the related measurement systems. The *static performance* of measurement systems is mainly defined by two measures: *accuracy* and *repeatability*. The *dynamic performance* is usually defined by the *settling time*.

3.1.1 Accuracy

Accuracy is the degree of closeness of measurements x of a quantity to that quantity's true value x_{true} . For most measurement systems, accuracy is specified by declaring maximum magnitude values for the *absolute* measurement error⁴

$$E \equiv x - x_{true} .$$

Alternatively, accuracy can be expressed *relative* to a reference value:

$$e \equiv \frac{E}{x_{ref}} = \frac{x - x_{true}}{x_{ref}} .$$

x_{ref} indicates a chosen reference value, usually the measurement range ($x_{ref} = x_{max} - x_{min}$) or the true value ($x_{ref} = x_{true}$)⁵. Maximum error values may be specified globally, or as a function of actual measurement x .

3.1.2 Repeatability

Repeatability is the closeness of agreement between independent measurement readings obtained with the same measurement system under the same conditions (for example same flow and same environmental conditions). Very often repeatability is defined as the value below which the absolute difference $|\Delta x| \equiv |x[k] - x[k - 1]|$ between two successive single measurements $x[k]$ and $x[k - 1]$ obtained under the same conditions may be expected to lie with a specified probability such as 95%.

Repeatability does not imply accuracy: the absolute difference Δx may be very low, but it is possible for every single measurement $x[k]$ and $x[k - 1]$ to be incorrect. *On the other hand, accuracy implies repeatability:* if a measurement system is accurate, $x[k]$ and $x[k - 1]$ show small deviations from the true value, and therefore the scatter of readings must also be small. Requiring a given accuracy is therefore always a more severe constraint than requiring a given repeatability.

3.1.3 Settling Time

Accuracy and repeatability describe the static performance of a measurement system. The most important parameter describing the *dynamic* performance is the settling time T_s , the time required for the response curve to reach and stay within a range of certain percentage (usually 5% or 2%) of the final value. Fast measurement systems are characterized by small settling times.

⁴ This is true only for a deterministic approach. Within a statistical context, uncertainty should be used instead.

⁵ In many cases the actual value x can be used for x_{true} as an approximation.

3.2 Flow meters [ADEC]

With the exception of pressure monitoring method (Chapter 5.1), rarefaction wave method (Chapter 6) and leak monitoring in shut-in conditions (Chapter 9), flow meters are the most important measurement instruments for leak detection. Several different types of flow meter are used on pipelines including:

- Orifice plates (differential pressure),
- Turbine meters
- Positive displacement meters
- Direct mass flow meters (Coriolis type)
- Ultrasonic meters

3.2.1 Orifice Plate

The flow meters most commonly installed on pipelines are sharp-edged orifice plates, a differential pressure type of meter. Although these meters are very common in applications such as the measurement of natural gas, their use as accurate instrumentation for pipeline leak detection is questionable. The biggest problem is their measurement uncertainty. The basic uncertainty in the discharge coefficient of a well-installed orifice plate in factory condition is around 0.5%. The best-case uncertainty in a fiscal gas application with all necessary secondary measurements taken into account is closer to 1%, conditional on regular inspection and occasional replacement of the plate. In installations not to fiscal standard it is reasonable to expect accuracies of around 3 – 5%.

The reading of an orifice plate depends on the density as well as the flow. It is common practice in low-accuracy measurements to perform a simple square-root extraction in a transmitter using an assumed constant value of density. This is not normally sufficiently accurate and stable for leak detection, and a flow computer should therefore be considered.

3.2.2 Turbine Meter

Turbine meters are flow-measuring devices with fan-like rotors that sense the velocity of flowing fluid in a closed conduit. The fluid force on the rotor causes it to rotate at a rate that depends mainly on volumetric flow rate, although also on friction forces and other factors. Over some range of conditions, the rate of rotation is nearly directly proportional to the rate of flow. Turbine meters are used extensively on pipelines, especially those carrying petroleum hydrocarbons. The total theoretical uncertainty of mass flow in a fiscal turbine meter system is around 0.25%, although this is an upper bound and practical figures as low as 0.05% can be achieved. Turbines are sensitive to viscosity, and most types perform less well above about 20cP. Their settling time is far faster than might be expected.

3.2.3 Positive Displacement Meter

Positive displacement meters measure flow by dynamically trapping fluid parcels of known volume in one or more measuring chambers. The biggest uncertainty factor with this type of meter is the unmeasured fluid slippage through its seals and clearances. This varies as the meter wears, so regular proving and fairly frequent servicing are both important. Although gas positive displacement meters exist, the main pipeline application for this meter type is relatively viscous liquids. In this case, the expected uncertainty is again around 0.25% for a fiscal system.

3.2.4 Coriolis Mass Meter

Coriolis direct mass meters are slowly gaining acceptance and being incorporated into the pipeline industry. The uncertainty of these instruments is approximately $\pm 0.5\%$ of reading or better. This type of meter has the advantage of providing direct mass measurement, which means that additional measurements of temperature, pressure, and density measurement or an equation of state to determine fluid density are not necessary. Coriolis meters can be applied to both liquid and gas, and are insensitive to viscosity. Their principal disadvantage is that they are very cumbersome and expensive in medium sizes, and large sizes are only starting to be available. It is also more difficult to check a mass meter against a prover, which is by nature a volumetric reference.

3.2.5 Ultrasonic Meter

Ultrasonic flow meters are available in Doppler and Transit Time types, but only the second of these is widely considered suitable for pipeline applications. Transit Time ultrasonic meters rely on accurate timing of ultrasonic impulses that cut across the pipe diagonally, and whose travel time across the meter therefore depends on the rate of flow. Ultrasonic meters do not directly measure the average velocity distribution in the pipe, and so require multiple paths to integrate the volume flow properly. Generally more paths imply better velocity distribution (or Reynolds number) compensation, although some meters have multiple equivalent paths whose function is to compensate for installation effects. Ultrasonic meters are available for both gas and liquid. The latest gas ultrasonic technology gives the best performance of any measurement principle, with uncertainty as low as 0.2%. Liquid ultrasonic meters give uncertainties similar to turbines, but with a higher viscosity cut-off. One of the major advantages of ultrasonic meters is little or no pressure loss.

4 Supervisory Control and Data Acquisition (SCADA)

Internal LDSs require field information such as flow, pressure and temperature that will be provided by means of *measurement stations* located at inlet, outlet and intermediate stations. Measurement stations at the inlet and outlet are called *head stations*, intermediate stations are called *substations*. This field information will usually be provided by a Supervisory Control and Data Acquisition (SCADA) system; this is a computer-based data communication system that monitors, processes, transmits, and displays pipeline data for the pipeline controller [ADEC]. SCADA systems may be used directly for leak detection, may provide support for an LDS, or an LDS may operate independently of SCADA. Generally, a pipeline LDS will use the data generated by a SCADA system.

4.1 Components of a SCADA System

Regardless of the manufacturer, SCADA systems are generally based on similar components.

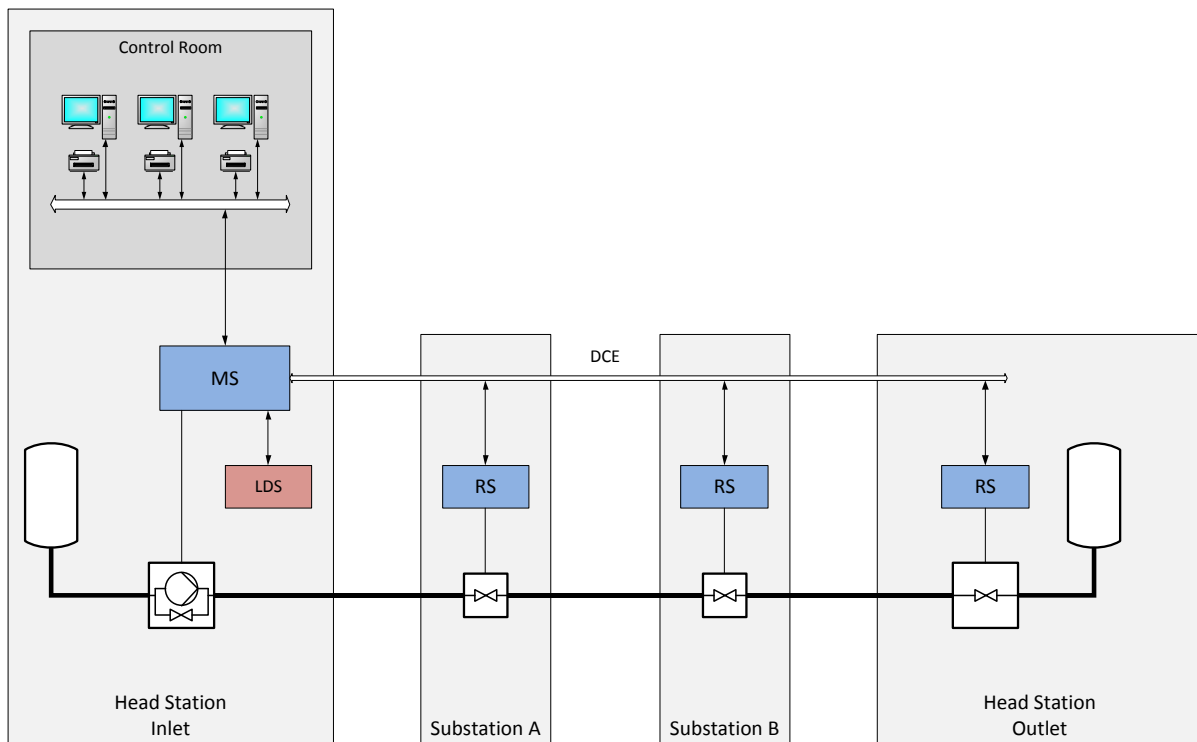

Figure 1: SCADA system for an example application

Figure 1 shows an example with two head stations (inlet and outlet) and two substations. The inlet head station is a pumping station, and the outlet head station is a valve station (for example with a pressure control valve). Two substations with valves permit fast flow shutoff in case of an emergency. The SCADA system collects real-time data from field instruments using *remote stations* (RSs) at substations and outlet head station. RSs acquire data from field instruments such as flow meters, often via analogue 4 -20mA current loop or communication protocols such as Modbus. *Programmable logic controllers* (PLCs) usually form part of RSs when local monitoring and control functions are necessary. RSs are sometimes called *remote terminal units* (RTUs) if only data acquisition is provided.

A *master station* (MS) at the inlet head station is connected to the RSs using *data communication equipment* (DCE). In most cases, the MS provides an Ethernet TCP/IP Local Area Network (LAN) in order to connect equipment for data presentation and human interaction; through this, the pipeline controller monitors and controls the system.

In the example of Figure 1 the LDS acquires required field information (flow, pressure, temperature and so on) from SCADA but otherwise operates independently. Data is transferred from SCADA to the LDS using a dedicated link, e.g. Modbus over serial connection (RS-232 or RS-485), Modbus over Ethernet TCP/IP, or OLE for Process Control (OPC). Nowadays OPC is becoming more and more the de facto industry standard. The LDS performs leak monitoring; the diagnostic results (leak no/yes, leak flow and position in case of a leak) are transferred back to the SCADA. Usually results are presented to the pipeline controller who then takes the appropriate actions. For additional discussion of SCADA system design factors and their effects on the quality and timeliness of the data required by an LDS, see [API RP 1130].

4.2 Data Acquisition

Data acquisition (DAQ) converts analogue field signals into digital values for data processing. DAQ is part of RS and MS when field signals are analogue, very often in form of a 4 – 20mA current loop. The quality of the conversion heavily depends on the DAQ *resolution* which is the smallest increment of signal change that can be determined by the device, and the full-scale range of the field signal. If the complete field signal range is assigned to 4 – 20mA and the DAQ resolution is specified with n bits, then the *absolute resolution* is given by

$$E = \frac{20mA - 4mA}{2^n} = \frac{16mA}{2^n}$$

yielding a *relative resolution* of

$$\varepsilon = \frac{E}{20mA - 4mA} = \frac{1}{2^n}.$$

Experience shows that DAQ resolution should be $n = 12$ bit or better. It is also important to use the full 4 – 20mA range.

4.3 Data Communication Equipment (DCE)

Data communication equipment (DCE) includes phone and radio modems as well as fiber optic, microwave and satellite transmission equipment. Messaging between the RS and MS is known as the *communications protocol* including handshaking, error detection, and error recovery. Leak monitoring is safety-relevant; it therefore could be necessary to provide redundant communication links to ensure that leak monitoring will continue in case of a connection failure.

4.3.1 Topology

Topology is the geometric arrangement of nodes and links that make up a network. For a SCADA system, these topologies are commonly used:

- *Point-to-Point*. This is a communication link between only two stations. Either station can initiate communication with the other, or one station can act as master.
- *Point-to-Multipoint*. This is a communication link among three or more stations with one station being a communication arbitrator (master) that controls when the other stations (remote stations acting as slaves) can communicate.
- *Multipoint-to-Multipoint*. This is a communication link among three or more stations where there is no communication arbitrator (master) and any station can initiate communications with any other station.

4.3.2 Communication Protocol

A communication protocol governs the format of data transmission between two or more stations, including handshaking, error detection, and error recovery. Leak monitoring is safety-relevant, so special attention is required concerning error detection and recovery. Transmission mode may be *half-duplex* (information is sent in one direction at a time over the link) or *full-duplex* (information is simultaneously sent and received over the link).

The protocol is considered *polled* when the MS requests data from each device consecutively. When the last device is scanned, the MS will automatically request information from the first one, creating a continuous polling cycle. The duration of this cycle, the SCADA system polling time, has steadily improved over the years and can now be less than 0.25 seconds. SCADA communications may also be *non-polled*. For example, RSs may report without being polled on a time-scheduled basis or when field conditions change.

LDSs that rely on the SCADA system to receive operating data are directly affected by the polling time. Longer polling cycles typically translate to degraded leak detection sensitivity. Most modern SCADA systems include quality checking software to assess the validity of the data before any calculations are computed and displayed. For model-based LDS, time-tagging may be required.

4.3.3 Link Media

Field information is transferred using specific physical link media such as:

- Public transmission media such as public switched telephone networks (PSTN), private leased lines (PLLs) and digital data services (DDS)
- Atmospheric media such as microwave radio, VHF/UHF radio and geosynchronous satellites
- Fiber-optical cable

The choice of link media depends on:

- Data transmission needs of the application
- Remote site and control center locations
- Distance between stations
- Available link media services
- Project budget

5 Pressure/Flow Monitoring

A leak changes the hydraulics of the pipeline, and therefore changes flow or pressure readings after some time [Krass/Kittel/Uhde]. Local monitoring of pressure or flow at only one point can therefore provide simple leak detection. It requires no telemetry, for example to compare flow rate at inlet and outlet, as local monitoring of pressure or flow rate is sufficient. It is only useful in steady state conditions, however, and its ability to deal with gas pipelines and multi-product liquid pipelines is extremely limited. It does not provide good sensitivity, and leak localization is not possible.

5.1 Pressure Monitoring

If a leak occurs, the pressure in the pipeline will fall by an amount Δp . As pressure sensors are almost always installed, it is natural to use them for leak detection. The pressure in the pipeline is simply compared against a lower limit after reaching the steady state condition. When the pressure falls below this lower limit, a leak alarm is raised.

5.2 Flow Monitoring

The sensitivity of the pressure monitoring method depends on the leak location. Near the inlet and the outlet of the pipeline a leak leads to little or no change in pressure. This can be avoided by flow monitoring, where the flow is measured for change. The two methods can be combined.

5.3 Summary

The next subchapters summarize the most important requirements and characteristics. See Chapter 14 for a comparison of all methods introduced in this survey.

5.3.1 Functionality and Instrumentation

Method	Function	Instrumentation		
		Complexity	Requirements Static	Dynamic
Pressure/Flow Monitoring				
Pressure Monitoring	LD	1 x P	Accuracy	None
Flow Monitoring	LD	1 x Q	Accuracy	None

Table 3: Functionality and instrumentation of pressure and flow monitoring⁶

Both methods provide leak detection, but no leak localization. (For details about leak localization see Chapter 10.) For pressure monitoring only one pressure sensor is required, and for flow monitoring only one flow meter is required. No statistical procedure is involved so accuracy is important (instead of repeatability). There are no special requirements concerning the dynamic transmission behavior.

5.3.2 Fields of Application

Method	Application		Medium	TRFL
	Pumping	Dynamics		
Pressure/Flow Monitoring				
Pressure Monitoring	PC, SC	Steady	Liquids + Gases	a), c)
Flow Monitoring	PC	Steady	Liquids + Gases	a)

Table 4: Fields of application of pressure and flow monitoring⁷

Pressure monitoring is able to detect leaks in pumping conditions as well as in shut-in conditions; for shut-in conditions, this will be true if the pipeline valves seal tightly enough. (For shut-in operation, there is a modified version called the *pressure-temperature method*, which takes into account the actual fluid temperature. For details see Chapter 9.)

⁶ LD = Leak detection, P = Pressure sensor, Q = Flow sensor.

⁷ PC = Pumping conditions, SC = Shut-in conditions

In contrast, flow monitoring is only able to detect leaks in pumping conditions. Both methods are restricted to the steady state, as small changes in pressure or flow will cause a false alarm. Either method is capable of monitoring gas and liquid pipelines. Pressure monitoring meets the following requirements of TRFL:

- TRFL a), a continuously-working system, which can detect leaks in steady state conditions
- TRFL c), a system to detect leaks in shut-in conditions

In contrast, flow monitoring only achieves TRFL a).

5.3.3 Performance Parameters

Method	Sensitivity			Leak Types
	Alarm Threshold	Time to Detect		
		Liquid	Gas	
Pressure/Flow Monitoring				
Pressure Monitoring	High	Short	Long	Sudden + Graduate
Flow Monitoring	High	Short	Long	Sudden + Graduate

Table 5: Performance parameters of pressure and flow monitoring

Both methods will work without malfunction if pressure and flow stay sufficiently constant in daily operation. This is true for some liquid pipelines, but hardly ever for gas pipelines.

These simple methods normally do not use sophisticated statistical methods to prevent false alarms (Chapter 8). The only way to avoid false alarms is therefore to set wide alarm limits. This causes a short time to detect a leak within liquid pipelines. In gas pipelines pressure changes are rather slow, so leak detection is slow. Both methods detect sudden leaks as well as gradual leaks of sufficient size.

6 Rarefaction Wave Method

A sudden leak caused, for example, by careless use of an excavator, leads to a *negative pressure wave* propagating at the speed of sound c up- and downstream through the pipeline. Such a wave, called a *rarefaction wave*, can be recognized using installed pressure transmitters, giving a leak alarm. It is also possible to calculate the leak location by timing the arrival of the pressure wave at two or more points on the pipeline (Chapter 10).

6.1 Summary

The next subchapters summarize the most important requirements and characteristics. See Chapter 14 for a comparison of all methods introduced in this survey.

6.1.1 Functionality and Instrumentation

Method	Function	Instrumentation		
		Complexity	Requirements Static	Dynamic
Rarefaction Wave (Negative Pressure Wave)				
Rarefaction Wave	LD + LL	2 x P	Repeatability	Very fast

Table 6: Functionality and instrumentation of rarefaction wave method⁸

At least two pressure transmitters are needed for leak localization; one pressure transmitter allows leak detection only. (For details about leak localization see Chapter 10.) In either case, the selected transmitters must be capable of detecting rapid changes in pressure and therefore must be very fast (very low settling time). On the other hand, repeatability rather than accuracy is important.

6.1.2 Fields of Application

Method	Application		Medium	TRFL
	Pumping	Dynamics		
Rarefaction Wave (Negative Pressure Wave)				
Rarefaction Wave	PC, SC	Steady	Liquids	a), c), e)

Table 7: Fields of application for rarefaction wave method⁹

The rarefaction wave method is able to detect leaks in pumping conditions as well as in shut-in conditions. It is only able to detect leaks in the steady state condition, and small variations in pressure can easily lead to false alarms. Rarefaction wave methods are most useful in liquid pipelines, as pressure waves are quickly attenuated in gas pipelines. This technique meets the following TRFL requirements:

- TRFL a), a continuous working system, which can detect leaks within steady state conditions
- TRFL c), a system to detect leaks in shut-in conditions
- TRFL e), a system or procedure to detect the leak position

6.1.3 Performance Parameters

Method	Sensitivity			Leak Types
	Alarm Threshold	Time to Detect		
		Liquid	Gas	
Rarefaction Wave (Chapter 6)				
Rarefaction Wave	High	Very Short	N/A	Sudden

Table 8: Performance parameters of rarefaction wave method

This technique will work without malfunction if pressure stays sufficiently constant in daily operation, which is true for some liquid pipelines but hardly ever for gas pipelines. Sophisticated statistical methods to prevent false alarms (Chapter 8) will not normally be used. The only way to avoid false alarms is therefore to set wide alarm

⁸ LD = Leak detection, LL = Leak localization, P = Pressure sensor

⁹ PC = Pumping conditions, SC = Shut-in conditions

limits. This causes a very short time to detect a leak within liquid pipelines. This method only detects sudden leaks of sufficient size.

7 Balancing Methods

Balancing methods are based on the principle of *conservation of mass*. In the steady state, summed over a sufficiently long time period Δt , the mass ΔM_I entering a leak-free pipeline at inlet will balance the mass ΔM_O leaving it at outlet. In the more general case, the difference in mass at the two ends must be balanced against the change of mass inventory of the pipeline ΔM_{Pipe} . Over any given period of time Δt , we can therefore say

$$\Delta M_I - \Delta M_O = \Delta M_{Pipe} \Leftrightarrow \Delta M_I - \Delta M_O - \Delta M_{Pipe} = 0 \quad (1)$$

if there is no leak, or, alternatively,

$$\dot{M}_I - \dot{M}_O = \frac{dM_{Pipe}}{dt} \Leftrightarrow \dot{M}_I - \dot{M}_O - \frac{dM_{Pipe}}{dt} = 0 \quad (2)$$

when dividing Eq. (1) by Δt and $\Delta t = dt \rightarrow 0$. Eq. (2) is the instantaneous version of Eq. (1). Here, \dot{M}_I and \dot{M}_O are mass flow at inlet and outlet, respectively, and dM_{Pipe}/dt is the change of mass inventory per unit time. The mass in the pipe is given by

$$M_{Pipe} = \bar{\rho} \cdot V_{Pipe}$$

where V_{Pipe} is the volume of the pipeline, and

$$\bar{\rho} \equiv \frac{1}{L} \cdot \int_0^L \rho(s) ds$$

is the mean product density along the pipeline of length L . $\rho(s)$ denotes the local density profile along the pipeline with space coordinate s , $0 \leq s \leq L$.

Any additional mass imbalance indicates a leak. This can be quantified by rearranging Eq. (1) and adding a term for leak mass yielding

$$\Delta M_{Leak} = \Delta M_I - \Delta M_O - \Delta M_{Pipe} \quad (3)$$

where ΔM_{Leak} denotes the mass lost by the leak during Δt , or, using Eq. (2)

$$\dot{M}_{Leak} = \dot{M}_I - \dot{M}_O - \frac{dM_{Pipe}}{dt} \quad (4)$$

where \dot{M}_{Leak} denotes the instantaneous leak mass flow. These equations are valid for liquid and gas pipelines in any consistent mass units.

7.1 Some Comments on Definitions

Balancing methods are very common so many references address this topic. Examples of definitions found in the literature include:

- Mass balance
- Material balance
- Line balance
- Volume balance
- Modified or compensated volume balance

Unfortunately, some of the listed definitions are misleading. Volume balance, for example, might sometimes be confused with mass balance. *But there is no principle of conservation of volume*, so

$$\Delta V_I - \Delta V_O \neq 0 \quad (5)$$

for leak-free pipelines even for $\Delta t \rightarrow \infty$ and ideal steady state conditions. (ΔV_I and ΔV_O are the volumes entering and leaving the pipeline during Δt , respectively.)

Definitions used with this survey consider strictly the physical facts thereby insuring consistency.

7.1.1 Mass Balance

Balancing methods in general are mass balance methods because the principle of conservation of mass is used. If volume flow is measured instead of mass flow, these methods generally have to consider the density at the inlet and the outlet, see Chapter 7.4. If changes in the mass inventory of the pipeline ΔM_{pipe} are not considered these are called *uncompensated mass balance methods* (Chapter 7.2), and otherwise *compensated mass balance methods* (Chapter 0).

7.1.2 Volume Balance

If densities ρ_I and ρ_O at inlet and outlet are equal, then

$$\Delta V_I - \Delta V_O = 0$$

for leak-free pipelines and $\Delta t \rightarrow \infty$. This is only true for single-product pipelines where pressure and temperature at inlet and outlet are equal. The method relying on these assumptions is called the *volume balance method*, but there still is no relation equivalent to Eq. (3) and (4), so change of inventory cannot be compensated. Another approach uses

$$\Delta V_I - \Delta V_O = \Delta V = \text{const.}$$

which means that leak-free volume imbalance is considered to be constant. A leak changes the offset ΔV leading to a leak alarm declaration using statistical procedures. For details on volume balance see Chapter 7.6.

7.1.3 Line Balance

Line Balance is a generic term covering all balancing methods (mass balance or volume balance).

7.2 Uncompensated Mass Balance

Supposing that a leak was allowed to continue for an infinitely long period, the mass entering and leaving the pipeline would increase indefinitely. The mass inventory of the pipeline, on the other hand, remains within a fixed range. ΔM_{pipe} therefore becomes negligible, and Eq. (3) reduces to

$$\Delta \hat{M}_{Leak} = \Delta M_I - \Delta M_O \quad (6)$$

which is the basic formula of uncompensated mass balance. $\Delta \hat{M}_{Leak}$ is now an *estimate* for the true value ΔM_{Leak} in Eq. (3). Over a finite period Δt , this equation is an approximation. Furthermore, errors in mass flow calculation must be considered, finally yielding the leak declaration rule

$$\Delta \hat{M}_{Leak} = \Delta M_I - \Delta M_O \begin{cases} > \gamma \cdot \Delta t & \Rightarrow \text{Leak} \\ \leq \gamma \cdot \Delta t & \Rightarrow \text{No Leak} \end{cases} \quad (7)$$

where γ is the leak *mass flow* threshold. For operation without false alarms, the time period Δt must be sufficiently long for the flow in and out of the pipeline to be large in comparison with the change in pipeline inventory. In the following cases, a very large value will be required:

- Starting and stopping pumps or compressors during start-up and shutdown
- Valve operation anywhere before, along or beyond the monitored pipeline segment
- Flow or pressure control actions
- Changes of target throughput
- Special cases such as cavitation
- Most gas pipelines, most of the time

For the calculation of ΔM_I and ΔM_O in Eq. (7), mass flows \dot{M}_I and \dot{M}_O will be used in most cases using $\Delta M = \bar{M} \cdot \Delta t$ where \bar{M} is the mass flow mean value during Δt .

7.3 Compensated Mass Balance

Unlike the uncompensated mass balance, the compensated mass balance takes account of changes in pipeline inventory; introducing ΔM_{Pipe} in Eq. (7) therefore gives

$$\Delta \hat{M}_{Leak} = \Delta M_I - \Delta M_O - \Delta M_{Pipe} \begin{cases} > \gamma \cdot \Delta t & \Rightarrow \text{Leak} \\ \leq \gamma \cdot \Delta t & \Rightarrow \text{No Leak} \end{cases} \quad (8)$$

where inventory change ΔM_{Pipe} is given by

$$M_{Pipe} = \bar{\rho} \cdot V_{Pipe} = \left[\frac{1}{L} \cdot \int_0^L \rho(s) ds \right] \cdot V_{Pipe} \quad (9)$$

It is not possible to determine the density profile $\rho(s)$ along the pipeline directly. Three indirect approaches are described below.

7.3.1 Measurement of Pressure and Temperature along the Pipeline

A quantity n of pressure p_i and temperature T_i transmitters must be installed sufficiently closely, $1 \leq i \leq n$. The pipeline is then split into n segments of known volume ΔV_i at each transducer pair. For every segment, the density ρ_i is calculated using a thermodynamic equation of state¹⁰ appropriate to the product. Equivalent relations for gases are also available. Finally, mean density $\bar{\rho}$ in Eq. (9) will be calculated using ρ_i .

7.3.2 Determination Using a Steady State Model

There are (reasonably simple) mathematical models available for liquid pipelines as well as for gas pipelines. In liquid pipelines, a simple linear decrease in pressure can sometimes be assumed along the pipeline¹¹; temperature of the fluid can be assumed to equal ground temperature for long pipelines. Corresponding flow equations for gas pipelines, (assuming for example isothermal or adiabatic flow) are available [Bohl]. Using these state models together with the corresponding equation of state permits the calculation of density profile $\rho(s)$ and pipe inventory using Eq. (9).

7.3.3 Determination Using a Real-Time Transient Model (RTTM)

The most accurate method is to use a pipeline model that covers transient as well as steady state conditions. This allows the density to be determined at every point along the pipeline for the steady state and transient operation – see Chapter 11.

¹⁰ EOS (for Equation Of State) or PVT equation (for P = Pressure p , V = Specific Volume v , T = Temperature T) are synonyms.

¹¹ This assumes a horizontal pipeline of constant internal roughness and cross-sectional area. Other cases require a modified approach.

7.4 Use of Volumetric Flow Meters

It is not always practical to measure the mass flow in and out of the pipeline directly – for example, direct mass meters are only available in a limited range of sizes. It is possible to substitute volumetric flow meters, but the indicated volume flow must be multiplied by line density to derive the mass. Depending on the application, the options for obtaining density include:

- The density of fluids of known composition is known and constant, and therefore can be stored in a lookup table
- The density can be directly measured
- The density for crude oil and its products can be determined as a function of pressure and temperature using [API MPMS11], provided that a reference density is available
- The density of natural gas can be calculated using equations of state such as AGA8 if the relevant parameters are known or can be measured

Conversion calculations from volumetric flow to mass flow for commonly used volumetric flow meters are usually implemented in a flow computer.

7.5 Balancing at Standard Conditions

Where volumetric flow meters are used, it can be convenient to express the pipeline balance Eq. (6) in the form of standard volume V_s instead of mass M . The standard volume of a fluid of mass M is defined as the fluid volume at some fixed and agreed temperature T_s and pressure p_s , such as 1.01325 bar and 15°C (ISO standard conditions), and is given by

$$V_s \equiv \frac{M}{\rho_s} \quad (10)$$

The standard density ρ_s is simply the product density at standard conditions. It is fixed for pure products, and can otherwise be calculated from measurements using an equation of state. For uncompensated mass balance, using Eq. (7) together with Eq. (10) yields

$$\Delta \hat{V}_{s,Leak} = \Delta V_{s,I} - \Delta V_{s,O} \begin{cases} > \gamma_s \cdot \Delta t & \Rightarrow \text{Leak} \\ \leq \gamma_s \cdot \Delta t & \Rightarrow \text{No Leak} \end{cases} \quad (11)$$

where $\Delta V_{s,I}$ and $\Delta V_{s,O}$ denote volume entering and leaving during time period Δt referred to standard conditions, and $\Delta \hat{V}_{s,Leak}$ represents the leak volume at standard conditions. γ_s is the corresponding alarm threshold. For compensated mass balance, Eq. (11) can be modified accordingly.

7.6 Volume Balancing

Balancing methods in general rely on the mass conservation principle; flow meters must therefore provide mass flows directly (using Coriolis meters) or indirectly via volume flow combined with pressure and temperature, see Chapter 7.4. There are, however, some applications where volumetric flow meters can be used by applying *volume balancing*¹².

¹² In technical literature, terms "mass balancing" and "volume balancing" are often not used consistently.

7.6.1 Approximately Equal Density at Inlet and Outlet

In this case, assuming single-product operation, density at inlet and outlet is equal, so $\rho_I = \rho_O = \bar{\rho}$, and Eq. (7) becomes:

$$\Delta \hat{V}_{Leak} = \Delta V_I - \Delta V_O \begin{cases} > \gamma' \cdot \Delta t & \Rightarrow \text{Leak} \\ \leq \gamma' \cdot \Delta t & \Rightarrow \text{No Leak} \end{cases} \quad (12)$$

where γ' is the leak *volume flow* threshold. This only happens if temperature (and pressure for gases) at inlet and outlet are equal. Again, for operation without false alarms, the time period Δt must be sufficiently long given the flow in and out of the pipeline, see Chapter 7.2. For the calculation of ΔV_I and ΔV_O , volume flows \dot{V}_I and \dot{V}_O will be used in most cases using $\Delta V = \bar{V} \cdot \Delta t$ where \bar{V} is the mean volume flow during Δt .

7.6.2 Batch Change for Multi-Product Pipelines

During a batch change for multi-product pipelines, the product entering the pipeline is not the same as the product leaving. In this case, mass flows at the inlet and outlet can differ significantly even in the absence of significant transient effects. It may then be preferable to use volume balance Eq. (12) instead of mass balance Eq. (7).

7.7 Summary

This section summarizes the key requirements and characteristics of the methods introduced in this chapter. See Chapter 14 for a comparison of all methods covered by this survey.

7.7.1 Functionality and Instrumentation

Method	Function	Instrumentation		
		Complexity	Requirements Static	Dynamic
Balancing Methods				
Mass Balance uncompensated	LD	2 x Q	Accuracy	None
Mass Balance compensated Direct p and T measurement	LD	2 x (Q,P,T) n x (P,T)	Accuracy	None
Mass Balance compensated Steady state model	LD	2 x (Q,P,T); T _G	Accuracy	None
Mass Balance compensated RTTM	LD	2 x (Q,P,T); T _G	Accuracy	Fast
Volume Balance	LD	2 x Q	Repeatability	None

Table 9: Functionality and instrumentation for balancing methods¹³

All balancing methods require at least two flow meters, one at the inlet and the other at the outlet. All mass balance methods require mass flow, either directly or indirectly measured, see Chapter 7.4. Volume balancing requires volumetric flow meters. All methods provide leak detection, but no leak location. (For details about leak localization see Chapter 10.) When the change in pipeline inventory is compensated, additional pressure and temperature sensors are also needed.

There are no special requirements for dynamic transition behavior (settling time) except for RTTM based compensation which required fast instruments for flow and pressure to follow transient effects. For most versions accuracy is important (instead of repeatability). Volume balance only has to consider repeatability because this method uses statistical procedures to detect changes in the volume imbalance.

¹³ LD = Leak detection, Q = Flow sensor, T= Temperature sensor, P = Pressure sensor, T_G = Ground temperature sensor

7.7.2 Fields of Application

Method	Application		Medium	TRFL
	Pumping	Dynamics		
Balancing Methods				
Mass Balance uncompensated	PC	Steady	Liquids	a)
Mass Balance compensated Direct p and T measurement	PC	Steady + Low Transient	Liquids + Gases	a)
Mass Balance compensated Steady state model	PC	Steady + Low Transient	Liquids + Gases	a)
Mass Balance compensated RTTM	PC	Steady + Transient	Liquids + Gases	a), b)
Volume Balance	PC	Steady	Liquids	a)

Table 10: Fields of application for balancing methods¹⁴

Balancing methods can be used only in pumping conditions: use in shut-in conditions is not possible. Uncompensated mass balance and volume balance are only able to monitor in steady state conditions. Compensated mass balance is able to monitor for leaks in the presence of moderate transients. Uncompensated mass balance and volume balance are practically limited to liquid pipelines; compensated mass balance can monitor gas pipelines with some success. Balancing methods meet the following TRFL requirements:

- TRFL a), a continuously operating system that can detect leaks in steady state conditions

Only the RTTM compensated mass balance meets this TRFL requirement:

- TRFL b), a continuously operating system that can to detect leaks in transient conditions

7.7.3 Performance Parameters

Method	Sensitivity			Leak Types
	Alarm Threshold	Time to Detect		
		Liquid	Gas	
Balancing Methods				
Mass Balance uncompensated	Medium	Long	N/A	Sudden + Graduate
Mass Balance compensated Direct p and T measurement	Medium	Medium	Long	Sudden + Graduate
Mass Balance compensated Steady state model	Medium	Medium	Medium	Sudden + Graduate
Mass Balance compensated RTTM	Medium	Short	Short	Sudden + Graduate
Volume Balance	Medium	Long	N/A	Sudden + Graduate

Table 11: Performance parameters for balancing methods

All balancing methods achieve a medium detection limit where accurate flow measurements are available. Uncompensated mass balance and volume balance have long detection times, while compensation for change of inventory helps to shorten the detection time. RTTM compensated mass balance shows the best results. Leak detection time is longer for gases because of the dynamic inertia of pressure and flow. All balancing methods detect sudden leaks as well as gradual leaks of sufficient size.

¹⁴ PC = Pumping conditions

8 Statistical Leak Detection Systems

Statistical LDSs use *statistical methods* to detect a leak. This gives an opportunity to optimize the decision if a leak exists in the sense of some chosen statistical criteria. However it makes great demands on measurements. They need to be *stationary* (in a statistical sense) for example. Statistical LDSs are therefore very well suited to steady state conditions, but put only provide limited sensitivity in transient states unless they are adapted, for example using a Real-Time Transient Models (RTTMs). PipePatrol E-RTTM (Chapter 13), for example, combines RTTM-technology (Chapter 11) with sophisticated statistical methods. Please refer to Chapter 13 for more details on this topic.

Statistical methods can improve the performance of all leak detection methods introduced in this survey. This Chapter describes statistical LDSs based on uncompensated mass balance, Chapter 7.2, because these systems are common [Zhang].

8.1 Hypothesis Testing

Statistical LDSs basing on hypothesis testing use methods and processes from *decision theory* [Barkat]. The *hypothesis test* for leak detection based on the uncompensated mass balance uses

$$\Delta\dot{M}[i] \equiv \dot{M}_I[i] - \dot{M}_O[i] \quad (13)$$

according to Eq. (2), where $\Delta\dot{M}[i]$ denotes sample i of the instantaneous imbalance between inlet and outlet mass flow. These samples can be used to decide between two hypotheses, H_0 and H_1 :

H_0 : No leak

H_1 : Leak

The statistical behavior of every individual sample is described by conditional probability density function $p(\Delta\dot{M} | H_0)$ for hypothesis H_0 (no leak) and $p(\Delta\dot{M} | H_1)$ for hypothesis H_1 (leak). A Gaussian (normal) distribution is generally assumed:

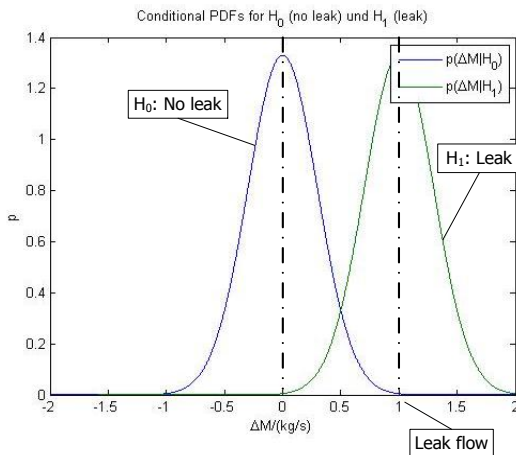

Figure 2: Conditional probability density functions (PDF)

8.1.1 Likelihood-Ratio Test (Probability-Ratio Test)

In statistics, a cause leads to a possible result with some *probability*. However a set of results implies a particular cause with some *likelihood*. For example, if a coin comes up heads six times in a row it would be possible to calculate the likelihood that the coin is biased. Although the term *probability ratio* is sometimes used for the type of test described here, likelihood ratio is more appropriate.

Instead of using one single sample $\Delta\dot{M}[i]$, a whole collection of data

$$\Delta\dot{\mathbf{M}} \equiv [\Delta\dot{M}_1 \dots \Delta\dot{M}_N] \quad \Delta\dot{M}_i \equiv \Delta\dot{M}[i]$$

will normally be used to increase the performance of the hypothesis test. The *likelihood-ratio test* is then given by

$$\Lambda(\Delta\dot{\mathbf{M}}) \equiv \frac{p(\Delta\dot{\mathbf{M}}|H_1)}{p(\Delta\dot{\mathbf{M}}|H_0)} \begin{cases} > \gamma & \Rightarrow H_1 \text{ (Leak)} \\ \leq \gamma & \Rightarrow H_0 \text{ (No Leak)} \end{cases} \quad (14)$$

where $p(\Delta\dot{\mathbf{M}}|H_i)$ is the conditional probability density function (PDF) of $\Delta\dot{\mathbf{M}}$ for hypothesis H_i , and $\Lambda(\Delta\dot{\mathbf{M}})$ is the *likelihood ratio* of $\Delta\dot{\mathbf{M}}$. The value of γ must be chosen to satisfy appropriate statistical criteria, including:

- *Probability of false alarms.* A false alarm occurs if there is a leak declaration but there is no real leak. False alarm probability P_{FA} should be as small as possible.
- *Probability of missed alarms.* A missed alarm occurs if there is no leak declaration but there is a real leak. Missed alarm probability P_{MA} should also be as small as possible too.

The problem of choosing γ appropriately must be solved in all probability-ratio tests. Details can be found in [Kroschel] for example.

A likelihood-ratio test such as Eq. (14) requires a-priori knowledge of PDFs $p(\Delta\dot{\mathbf{M}}|H_i)$. In most cases, including leak detection, these PDFs are not known in advance. To solve this problem, a *generalized likelihood-ratio test* can be used instead. Here, PDFs $p(\Delta\dot{\mathbf{M}}|\hat{\theta}_i, H_i)$ have parameters θ_i such as the mean μ_i and standard deviation σ_i of a normal distribution. These can be estimated by some statistical procedure, for example by applying the maximum-likelihood method. For details, refer to [Kay].

8.1.2 Sequential Probability-Ratio Test (SPRT)

The likelihood-ratio test above relies on evaluating a whole collection of data $\Delta\dot{\mathbf{M}}$ in a single step, so applying it to online leak detection schemes would depend on establishing and maintaining data buffers. This inconvenience can be avoided using a sequential probability-ratio test (SPRT), see [Wald]. Here, $\Lambda(\Delta\dot{\mathbf{M}})$ will be computed recursively yielding

$$\Lambda(\Delta\dot{\mathbf{M}}[k]) = f(\Lambda(\Delta\dot{\mathbf{M}}[k-1]), \Delta\dot{\mathbf{M}}[k]).$$

8.2 Signature Analysis

The methods presented so far can be improved by using *statistical classification techniques* to analyze the *signature* of field signals influenced by the presence of a leak. As an example, three different imbalance signatures can be defined for:

- Step signature for sudden leaks
- Drift signature for gradual leaks or sensor drift
- All other types of signature

Statistical classification algorithms (see e.g. [Kay]) now determine the signature of $\Delta\dot{\mathbf{M}}$ by assignment to any of the classes a), b) or c). Using this technique leads to improved leak detection sensitivity while at the same time preventing false alarms. PipePatrol E-RTTM uses this approach, see Chapter 13.2.

8.3 Summary

This section summarizes the key requirements and characteristics of the methods introduced in this Chapter. See Chapter 14 for a comparison of all methods covered by this survey.

8.3.1 Functionality and Instrumentation

Method	Function	Instrumentation Requirements		
		Complexity	Static	Dynamic
Statistical LDS				
Mass Balance uncompensated Hypothesis Testing	LD	2 x Q	Repeatability	None

Table 12: Functionality and instrumentation for statistical LDS¹⁵

Statistical methods based on the uncompensated mass balance need two flow meters, one at the inlet and the other at the outlet. They provide leak detection, but no leak location (for details of leak localization see Chapter 10). There are no special requirements for dynamic behavior (settling time). Statistical LDSs only have to consider repeatability because these methods use statistical procedures.

8.3.2 Fields of Application

Method	Application		Medium	TRFL
	Pumping	Dynamics		
Statistical LDS				
Mass Balance uncompensated Hypothesis Testing	PC	Steady + Low Transient	Liquids + Gases	a)

Table 13: Fields of application for statistical LDS¹⁶

Statistical LDSs can be used in pumping conditions, but not in shut-in conditions. Statistical LDSs are able to operate in moderately transient states, but with increased leak detection time. Statistical LDSs provide moderate performance on gas pipelines. They meet the following requirements:

- TRFL a), a continuous working system, which can detect leaks within steady state conditions

8.3.3 Performance Parameters

Method	Sensitivity			Leak Types
	Alarm Threshold	Time to Detect Liquid	Time to Detect Gas	
Statistical LDS				
Mass Balance uncompensated Hypothesis Testing	Low	Long	Very Long	Sudden + Graduate

Table 14: Performance parameters for statistical LDS

Statistical LDS have a low alarm limit, but time to detect is comparatively long. Statistical methods detect sudden leaks as well as gradual leaks of sufficient size.

¹⁵ LD = Leak detection, Q = Flow sensor

¹⁶ PC = Pumping conditions

9 Leak Monitoring during Shut-In Conditions

There are two main pipeline conditions:

- *Pumping conditions*, where the product will be transported by means of fluid flow
- *Paused Flow conditions*, where fluid flow is (near) zero.

The focus of the methods presented up to now was on pumping conditions, but leak monitoring in paused flow conditions is also important if pause times cannot be neglected. In particular, this applies to multi-product pipelines where pause times between two batches may be significant. In some applications valves will be used to block the fluid flow in the monitored segment. This special paused flow condition will be called *shut-in* or *blocked-line* condition.

9.1 PT – Pressure-Temperature Method

In shut-in conditions, valves will lock a pressure into one or more sections of the pipeline. It is possible for considerable pressure changes to occur in this case as a result of thermal effects, but any rapid or unexpected fall in pressure indicates that a leak has occurred.

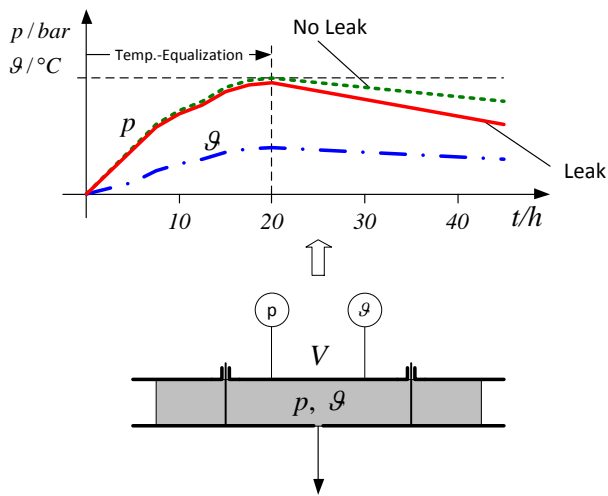

Figure 3: Leak detection during shut-in by PT method

After closing the valves, during temperature equalization, transient effects decay and fluid pressure p and fluid temperature ϑ approach their equilibrium values. If there is no leak, the resulting pressure trend only depends on fluid temperature as shown in Figure 3, where the green no-leak line indicates a pressure drop as a consequence of a temperature drop. Leak testing is performed by balancing changes in the measured pressure in the test section against theoretical pressure changes calculated from the measured temperature in the test section. This is therefore called the PT method.

The PT method can be used for *hydrostatic testing* where the pipeline segment is filled with water. Hydrostatic testing is regulated in many countries, for example in case of a new pipeline installation, a pipeline relocation, replacement of existing pipeline segments, or when there are other changes to a pipeline system which may affect integrity [VdTÜV 1051].

9.2 DP – Differential Pressure Method

For pipelines, the PT method can be refined to the differential-pressure method (DP method).

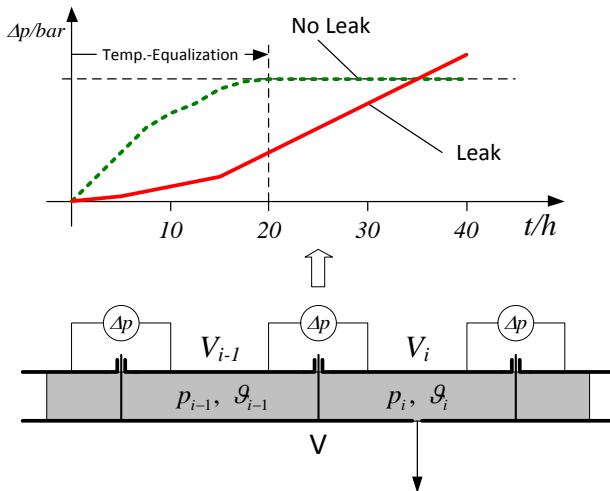

Figure 4: Leak detection during shut-in by DP method

Some time after the valves are closed the pressure p_i and temperature ϑ_i of segment i come close to their equilibrium values. We now observe the differential pressure Δp across the tightly closed valve V . If there is no leak, Δp stays sufficiently constant (green line); in case of a leak, there is a significant pressure gradient (red line). Using differential pressure instead of absolute pressure as for the PT method leads to higher sensitivity but can only be used in case intermediate valve stations are present.

9.3 Summary

This section summarises the key requirements and characteristics of the methods introduced in this Chapter. See Chapter 14 for a comparison of all methods covered by this survey.

9.3.1 Functionality and Instrumentation

Method	Function	Instrumentation		
		Complexity	Requirements Static	Dynamic
Leak Monitoring during Shut-In Conditions				
PT-Method	LD	2 x (P,T)	Repeatability	None
DP-Method	LD	n x DP	Repeatability	None

Table 15: Functionality and instrumentation for leak monitoring during shut-in conditions¹⁷

Both methods provide leak detection, but no leak localization. (For details about leak localization see Chapter 10.) The PT method requires pressure and temperature sensors on both sides of the pipeline, whereas DP method requires a higher number of valve stations where differential pressure across tightly closed valves will be measured. There are no special requirements concerning the dynamic transition behavior (settling time). Both methods need only to consider repeatability because the change of (differential) pressure is analyzed.

¹⁷ LD = Leak detection, T= Temperature sensor, P = Pressure sensor, DP = Differential Pressure sensor

9.3.2 Fields of Application

Method	Application		Medium	TRFL
	Pumping	Dynamics		
Leak Monitoring during Shut-In Conditions				
PT-Method	SC	Steady	Liquids	c), d)
DP-Method	SC	Steady	Liquids	c), d)

Table 16: Fields of application for leak monitoring during shut-in conditions¹⁸

Both methods are able to detect leaks in shut-in conditions, if the pipeline valves seal tightly enough. They are restricted to steady state conditions as small changes in pressure will cause a false alarm. Both methods are particularly useful for liquid pipelines, and meet the following requirements of TRFL:

- TRFL c), a system to detect leaks in shut-in conditions
- TRFL d), a system or procedure to detect gradual leaks

9.3.3 Performance Parameters

Method	Sensitivity			Leak Types
	Alarm Threshold	Time to Detect		
		Liquid	Gas	
Leak Monitoring during Shut-In Conditions				
PT-Method	Low TRFL c)	Very Long	N/A	Sudden + Graduate
	Very Low TRFL d)			
DP-Method	Low TRFL c)	Very Long	N/A	Sudden + Graduate
	Very Low TRFL d)			

Table 17: Performance parameters for leak monitoring during shut-in conditions

Both methods provide a sensitive alarm threshold (in particular when used for gradual leak detection), but time to detect the leak is very long. Both methods are able to detect sudden leaks as well as gradual leaks of sufficient size.

¹⁸ SC = Shut-in conditions

10 Leak Localization

When a leak is detected, it is important to locate it. An exact leak location gives the opportunity to take swift containing action to minimize harm to people and the environment. Localized repairs can then be carried out cost-effectively.

10.1 Gradient Intersection Method

The gradient intersection method is based on the fact that the pressure profile along the pipeline with its length L will change significantly if a leak occurs¹⁹.

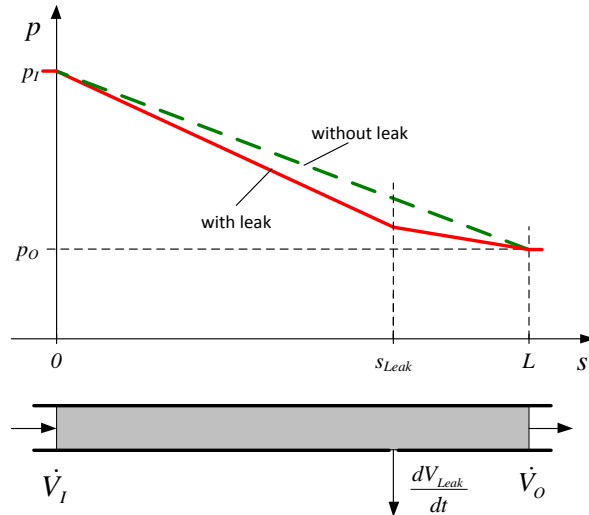

Figure 5: Leak location by gradient intersection method

The dashed, green line in Figure 5 shows the linear pressure drop in a leak-free liquid pipeline. The pressure profile is more complex for a gas pipeline, but a similar principle applies. If a leak occurs, the pressure profile develops a kink at the leak point – (continuous, red line). The leak location can be determined by calculating the intersection point of the pressure profiles upstream and downstream of the leak. The classic gradient intersection approach calculates the gradient of both lines using two pressure readings near the inlet and two pressure readings near the outlet. The model-based gradient intersection method, as used by PipePatrol E-RTTM LDS Chapter 13, calculates the two gradients with the help of the real time transient model, computed from flow and pressure measurements at inlet and outlet.

This method only achieves accurate results if the pipeline is in the steady state. The cause or development of the leak (sudden or gradual) does not matter.

10.2 Time-of-Flight Method

A sudden leak caused, for example, by careless use of an excavator, leads to a *rarefaction wave* propagating at the speed of sound c up- and downstream through the pipeline of given length L . Such a wave can be recognized using installed pressure transmitters, giving a leak alarm. The leak position can be determined²⁰ if the moment t_{down} (downstream) and t_{up} (upstream), when this negative wave passes the transmitters is measured. Setting $\Delta t \equiv t_{down} - t_{up}$, the estimated leak location is:

$$\hat{s}_{Leak} = \frac{1}{2} \cdot (L - c \cdot \Delta t). \quad (15)$$

The time-of-flight method needs an identifiable rarefaction wave. Results will be good if a leak is sufficiently large and sudden. Small and/or gradual leaks cannot be located by this method. In practical use, it is limited to steady state conditions. It is able to locate leaks in pumping or in paused flow conditions. PipePatrol E-RTTM uses the RTTM based gradient intersection method, which compensates transients leading to good results even in highly transient states.

¹⁹This is true for liquid pipelines with constant roughness height k_R , a constant cross-section A , and a horizontal built pipeline. The method must be modified in other cases.

²⁰ The speed of sound is not constant in liquid pipelines under multi-product conditions or in gas pipelines. The method has to be modified accordingly.

11 RTTM – Real Time Transient Model

RTTM means “Real-Time Transient Model”. Some LDSs of the PipePatrol-LDS-Family by KROHNE Oil & Gas are based on RTTM, also known as the “Pipeline Observer”. The KROHNE “flagship” is PipePatrol Extended Real-Time Transient Model (E-RTTM), which combines RTTM technology used for the residual-method (Chapter 11.2 and Chapter 11.3) with leak signature analysis to prevent false alarms, Chapter 13. PipePatrol Statistical Line Balance (SLB, Chapter 12) may alternatively be used if demand for sensitivity is reduced, if leak localization is not required, or as a fallback.

RTTM systems build mathematical models of the flow within a pipeline using basic physical laws such as:

- Conservation of mass
- Conservation of momentum
- Conservation of energy

When combined with an equation of state, introduced in Chapter 7, RTTM systems model transient and steady state flow in a pipeline. A transient state means that sudden changes in flow, pressure, temperature and density may occur. The changes propagate as waves through the pipeline with the speed of sound c of the fluid. For example, transient state occurs in a pipeline during:

- Start and stop of pumps or compressors during start-up and shutdown
- Valve operation anywhere before, along or after the monitored pipeline segment
- Flow or pressure control action
- Changes of throughput
- Special effects such as cavitation

Gas pipelines are almost always in a transient state, because gases are very compressible. Even in liquid pipelines transient effects cannot be disregarded most of the time.

An RTTM makes it possible to calculate mass flow, pressure, density and temperature at every point along the pipeline *in real-time* with the help of mathematical algorithms. These solutions are called *local profiles*.

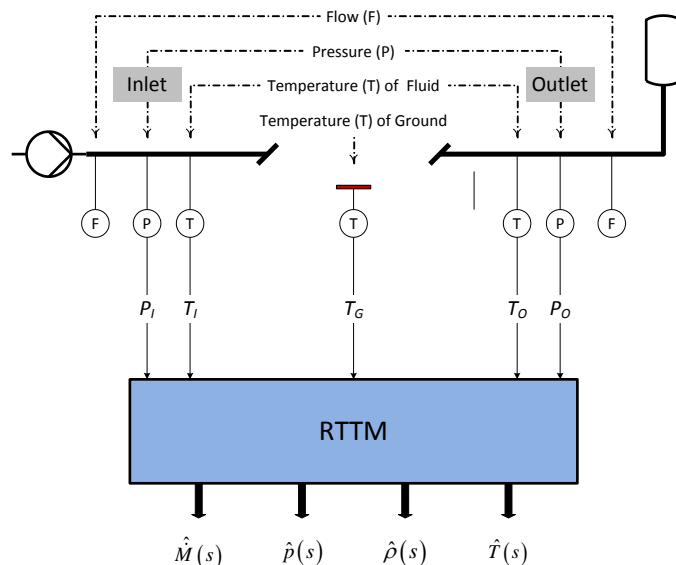

Figure 6: RTTM to calculate local profiles; model using pressure (and temperature) readings²¹

The simplest possibility for RTTM is shown in Figure 6. In this case only pressure (and temperature) at the head stations are fed into the RTTM, along with ground temperature if the pipeline is buried.

²¹ Subscripts are used as follows: "I" = inlet, "O" = outlet, "G" = ground. The "A" is used to indicate that the values are not measured, but calculated. The addition of (s) indicates that these are not simple point values, but profiles and therefore functions of the distance along the pipeline.

Calculation of the local profiles needs process measurements at the inlet (subscript I) and outlet (subscript O) of the pipeline – these points are known together as the “head stations”. Various combinations of measurement are possible, as we shall see in a moment. A value of ground temperature, T_G is also needed, assuming that the pipeline is underground. If ground temperature can be assumed constant along a pipeline in practice, one sensor may be used to measure a representative value.

It is also possible to implement the model using flow at the head stations instead of pressure:

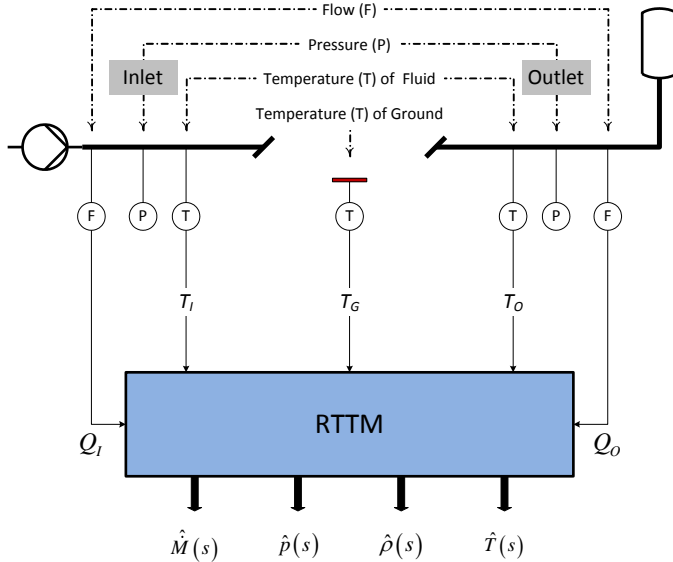

Figure 7: RTTM to calculate local profiles; model using flow (and temperature) readings²²

²² Q denotes flow either as mass flow or volume flow

11.1 Compensation Approach

It was mentioned in Chapter 0 that a compensated mass balance calculation needs to integrate the density ρ along the pipeline in order to determine the mass inventory of the pipe. The RTTM provides the necessary information to do so accurately, as shown in Figure 8.

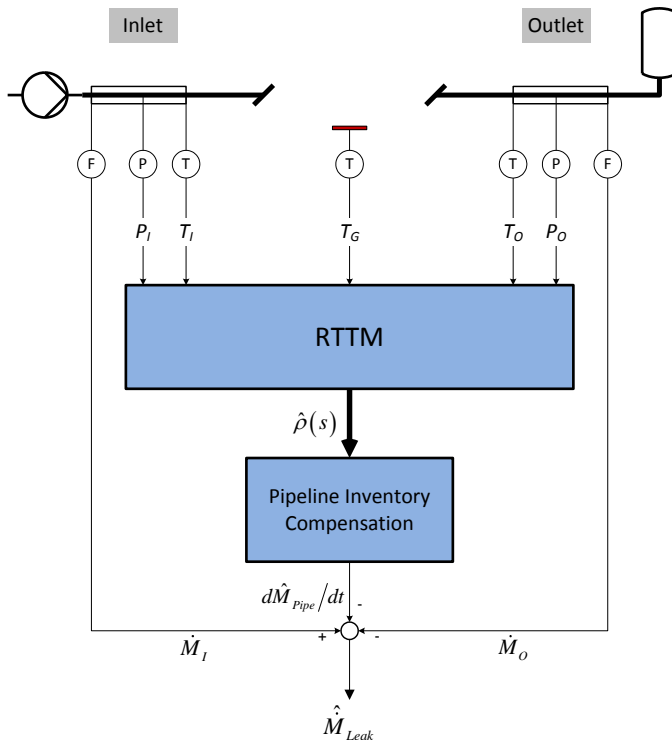

Figure 8: Compensated mass balance with RTTM based compensation²³

In this implementation, the RTTM calculates the density profile $\hat{\rho}(s)$ based on pressure and temperature at the head stations and ground temperature. Pipeline inventory then is calculated using Eq. (9)

$$\hat{M}_{Pipe} = \bar{\rho} \cdot V_{Pipe} = \left[\frac{1}{L} \cdot \int_0^L \hat{\rho}(s) ds \right] \cdot V_{Pipe}$$

where $V_{Pipe} = A \cdot L$ denotes the volume of the pipeline of length L , and $\bar{\rho}$ is the estimated mean density along the pipeline²⁴. Leaks will be detected using Eq. (8) or alternatively

$$\hat{M}_{Leak} = \dot{M}_I - \dot{M}_O - \frac{d\hat{M}_{Pipe}}{dt} \begin{cases} > \gamma & \Rightarrow \text{Leak} \\ \leq \gamma & \Rightarrow \text{No Leak} \end{cases} \quad (16)$$

Eq. (16) is the instantaneous version of Eq. (8); Figure 8 is therefore an example of an *compensated mass balance method*, in this case with RTTM based compensation.

PipePatrol Statistical Line Balance (SLB, Chapter 12) uses this technology together with statistical methods (Chapter 8).

²³ The flow needs to be mass flow here; if volume flow given, mass flow has to be calculated – see chapter 0.

²⁴ For simplicity, cross-section A had been assumed to be constant along the pipeline.

11.2 Flow Residual Approach

The flow at head stations in Figure 9 is not necessary to calculate the local profiles, as pressure is used for this purpose, see Figure 6. The RTTM calculates flow at the end points of the pipe as well as everywhere else. It is therefore possible to check the difference between *measured* and *calculated* flow. A difference between the two indicates a change in the dynamics of the pipeline – in other words, a suspicion that there may be a leak.

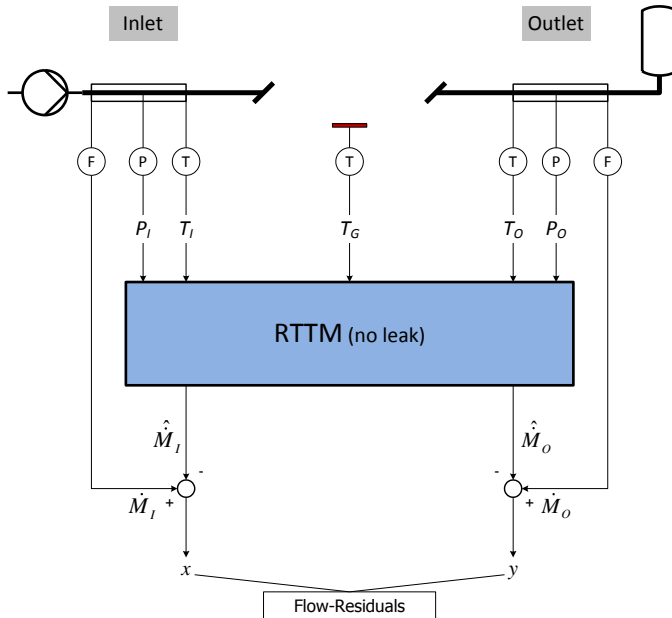

Figure 9: Flow residual approach²⁵

Both of the *Flow-Residuals* can be used as leak indicators:

$$x \equiv \dot{M}_I - \hat{\dot{M}}_I$$

$$y \equiv \dot{M}_O - \hat{\dot{M}}_O$$

The no-leak hypothesis H_0 is true if the indicated flows agree sufficiently closely with the model. The leak-present hypothesis H_1 is true if there is a positive residual at the inlet and/or a negative residual at the outlet.

Mathematically:

$$H_0 : \text{No leak} \Rightarrow x \approx 0, y \approx 0$$

$$H_1 : \text{Leak} \Rightarrow x > 0, y < 0$$

We insist on the appropriate signs for the residuals because a positive residual at the outlet, for example, would indicate that more fluid was leaving the pipeline than expected. In other words, the cases $x < 0$ and $y > 0$ would indicate a “negative leak”. This tells us something interesting about the performance of the instruments or the validity of the RTTM, but it is not a physically realistic basis for declaring a leak alarm.

PipePatrol E-RTTM (Chapter 13) uses this technology together with statistical methods (Chapter 8) for *head station monitoring* during pumping conditions, see Chapter 13.4.1.

²⁵ The flow here needs to be mass; if volume flow given, mass flow has to be calculated – see section 0.

11.3 Pressure Residual Approach

If a pipeline is long enough, substations with pressure sensors will often be included. The indicated pressures can be compared with those calculated using the RTTM method, giving *pressure residuals* as follows:

$$z_i \equiv p_i - \hat{p}_i, \quad 1 \leq i \leq n$$

Note that in Figure 10 temperature and flow measurement at the substations are unnecessary.

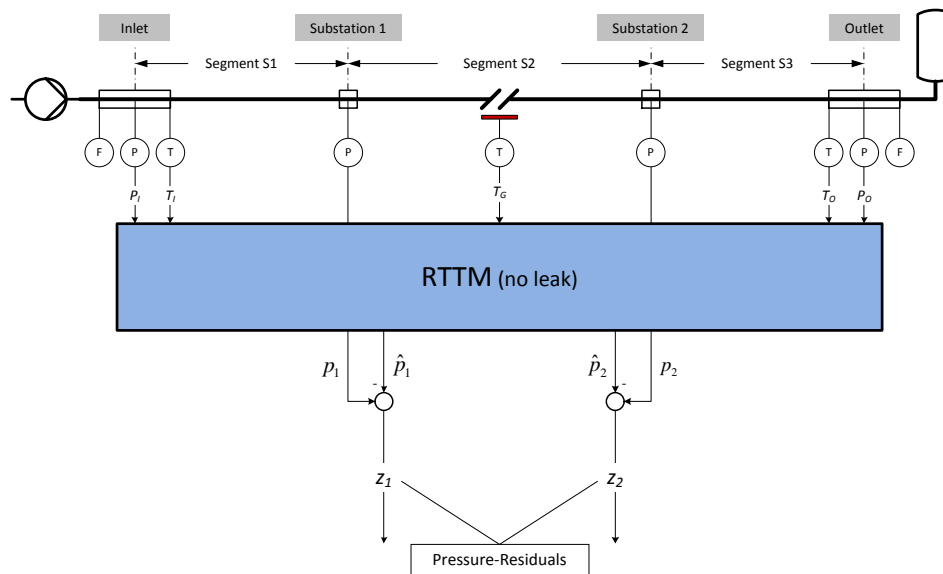

Figure 10: Pressure residual approach²⁶

The no-leak hypothesis H_0 is true if the indicated pressures agree sufficiently closely with the model. The leak-present hypothesis H_1 is true if there is a negative residual. Mathematically:

$$H_0 : \text{No leak} \Rightarrow z_i \approx 0$$

$$H_1 : \text{Leak} \Rightarrow z_i < 0$$

Again, we insist on the appropriate sign for the residual because a positive residual would indicate a “negative leak”, which implies an instrument problem.

²⁶ For a better point of view only two substations are shown. The method is able to handle as much substation as present at the pipeline.

12 PipePatrol Statistical Line Balance (SLB)

PipePatrol Statistical Line Balance (SLB) combines balancing methods (Chapter 7) with statistical classification methods (Chapter 8).

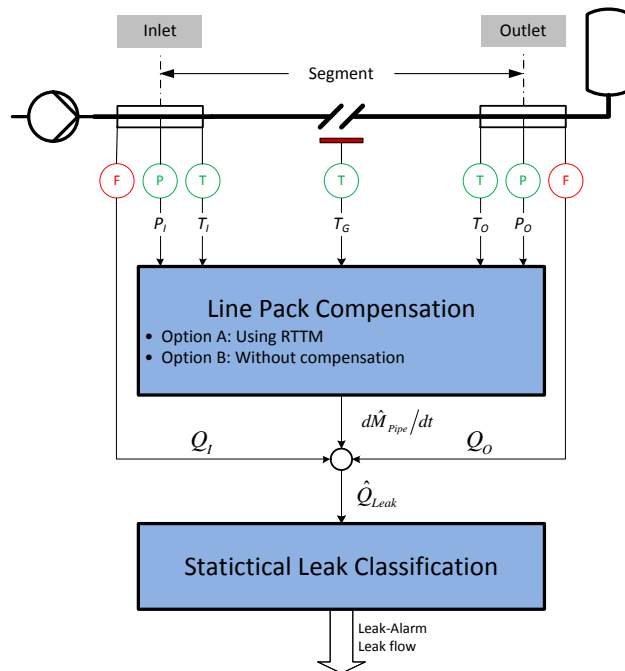

Figure 11: PipePatrol Statistical Line Balance (SLB)²⁷

PipePatrol SLB offers options to handle different application needs. Instruments shown with red symbols in Figure 11 are mandatory; instruments shown with green symbols are used if required for a specific application.

Depending on the chosen options, PipePatrol SLB can be classified as a *balancing method* (Chapter 7) and/or an *RTTM-based method* (Chapter 11). It applies compensated mass balancing (Chapter 0) or uncompensated mass balancing (Chapter 7.2) or alternatively volume balancing (Chapter 7.6). Estimates of the leak mass or volume will be analyzed by a *statistical leak classification* implementing the methods of a statistical LDS (Chapter 8).

In contrast to PipePatrol E-RTTM (Chapter 13), PipePatrol SLB does not provide leak localization. If there is high demand for sensitivity, PipePatrol E-RTTM should also be used instead. On the other hand, PipePatrol SLB may be used without pressure and temperature sensors if Inventory Compensation is omitted; PipePatrol SLB can therefore serve as a backup system for PipePatrol E-RTTM in case of a failure of a pressure or temperature sensor.

12.1 Pipeline Inventory Compensation

PipePatrol offers two different possibilities of pipeline inventory compensation:

12.1.1 RTTM Based Compensation (→Compensated Mass Balance LDS)

In its most sophisticated version, PipePatrol SLB applies RTTM-based inventory compensation using the compensation approach (Chapter 11.1). It is then a *compensated mass balance LDS* requiring full instrumentation: direct or indirect mass flow meters, pressure and temperature sensors at inlet and outlet. It then provides sensitivity close to that of PipePatrol E-RTTM.

12.1.2 No Compensation (→Uncompensated Mass Balance or Volume Balance LDS)

Inventory compensation optionally can be omitted completely; PipePatrol SLB is then an *uncompensated mass balance LDS*. This reduces sensitivity significantly, but requirements for instrumentation are also reduced: only flow meters at the inlet and outlet are required. In this configuration, PipePatrol SLB then can serve as a backup system for PipePatrol E-RTTM in case of a failure of a pressure or temperature sensor.

²⁷ Q denotes flow either as mass flow (for compensated and uncompensated mass balance) or volume flow (for volume balance). If necessary, the transformation of the volume flow to mass flow is done within PipePatrol – see Chapter 0.

Volume balancing using volumetric flow meters is also possible, see Chapter 7.6; PipePatrol SLB is then a *volume balance LDS*. This is particularly useful during batch change for multi-product pipelines, where different products are entering and leaving the pipeline. In that case, mass flows at inlet and outlet would differ significantly even in the absence of significant transient effects.

12.2 Statistical Leak Classification

An LDS that generates false alarms cannot be trusted, so it is a key task to eliminate them. PipePatrol SLB prevents them using *statistical leak classification* (see Chapter 8), which executes after the inventory compensation. This boosts the reliability and the robustness of the system without compromising sensitivity. False alarms are prevented, even with low alarm thresholds.

12.3 Summary

This section summarizes the key requirements and characteristics of the methods introduced in this Chapter. See Chapter 14 for a comparison of all methods covered by this survey.

12.3.1 Functionality and Instrumentation

Method	Function	Instrumentation		
		Complexity	Requirements Static	Dynamic
PipePatrol Statistical Line Balance (SLB), Krohne Oil & Gas				
Mass Balance compensated	LD	2 x (Q,P,T); T _G	Repeatability	Fast
Mass Balance uncompensated	LD	2 x Q	Repeatability	None
Volume Balance	LD	2 x Q	Repeatability	None

Table 18: Functionality and instrumentation for PipePatrol SLB²⁸

All configurations need at least two flow meters, one at the inlet and the other at the outlet. They provide leak detection, but no leak location. (For details about leak localization see Chapter 10.) If the change in pipeline inventory is compensated, additional instruments (pressure and temperature sensors) are required. PipePatrol SLB uses statistical leak classification; instrument repeatability is therefore of primary interest, rather than accuracy, which reduces specification requirements. Instrumentation must be fast (low settling time) for RTTM based compensated mass balance only in order to follow transient effects correctly.

12.3.2 Fields of Application

Method	Application		Medium	TRFL
	Pumping	Dynamics		
PipePatrol Statistical Line Balance (SLB), Krohne Oil & Gas				
Mass Balance compensated	PC	Steady + Transient	Liquids + Gases	a), b)
Mass Balance uncompensated	PC	Steady + Low Transient	Liquids	a)
Volume Balance	PC	Steady + Low Transient	Liquids	a)

Table 19: Fields of application for PipePatrol SLB²⁹

All configurations can be used in pumping conditions, but use under shut-in conditions is not possible. All configurations are capable of handling moderately transient states and liquid pipelines, but heavily transient states and gas pipelines can only be handled by adding RTTM-based inventory compensation. Volume balance will be used mainly for multi-product liquid pipelines. All configurations of PipePatrol SLB are capable of offering:

- TRFL a), a continuously operating system, which can detect leaks in steady state conditions

If pipeline inventory compensation is used, PipePatrol SLB is also able to offer:

- TRFL b), a continuously operating system, which is able to detect leaks in transient states

²⁸ LD = Leak detection, Q = Flow sensor, T = Temperature sensor, P = Pressure sensor, T_G = Ground temperature sensor

²⁹ PC = Pumping conditions

12.3.3 Performance Parameters

Method	Sensitivity			Leak Types
	Alarm Threshold	Time to Detect Liquid	Time to Detect Gas	
PipePatrol Statistical Line Balance (SLB), Krohne Oil & Gas				
Mass Balance compensated	Low	Short	Medium	Sudden + Graduate
Mass Balance uncompensated	Medium	Long	N/A	Sudden + Graduate
Volume Balance	Medium	Long	N/A	Sudden + Graduate

Table 20: Performance parameters for PipePatrol SLB

All configurations offer medium to low alarm thresholds. Time to detect a leak is long without pipeline inventory compensation, but shortens significantly if it is available. Time to detect a leak is longer for gas pipelines because of the dynamic inertia of pressure and flow. All configurations detect both sudden and gradual leaks of sufficient size.

13 PipePatrol Extended Real-Time Transient Model (E-RTTM)

PipePatrol E-RTTM is KROHNE's flagship LDS, which fuses the RTTM technology described in Chapter 11 with leak signature analysis described in Chapter 13.2 in a unique manner. For this reason it is called "Extended RTTM" [Geiger]. PipePatrol E-RTTM is able to monitor pipelines:

- During *pumping conditions* (PipePatrol E-RTTM/PC, Pumping Conditions, see Chapter 13.4)
- During *shut-in conditions* (PipePatrol E-RTTM/SC, Shut-In Conditions, see Chapter 13.5).

13.1 Pipeline Observer

PipePatrol E-RTTM uses the RTTM residual approaches presented in Chapter 11.2 (for pumping conditions) and Chapter 11.3 (for shut-in conditions). Within the context of PipePatrol E-RTTM, the RTTM modules in Figure 9 and Figure 10 are called *pipeline observer*³⁰, because they are observing the pipeline by calculating the local profiles for flow, pressure, fluid temperature and density.

Use of the RTTM pipeline observer compensates the transient behavior of the pipeline. Even in heavy transient states (for example during pipeline start-up) residuals stay close to zero in leak-free conditions. Sensitive leak detection is therefore possible in transient states.

13.2 Leak Signature Analysis

An LDS that generate false alarms cannot be trusted, so it is a key task to eliminate them. PipePatrol E-RTTM uses *leak signature analysis* (see Chapter 8.2), which executes after the pipeline observer, to prevent them. In this second stage residuals are analyzed for leak signatures:

- *Sudden leak*. This "classical leak" develops quickly for example by external damage to the pipeline. It causes a dynamic signature in residuals. When such a leak recognized, a leak alarm will be reported and the leak location and leak flow are determined.
- *Sensor drift or gradual leak*. These may occur by contamination of the flow meter or by small leaks caused by corrosion. They result in indistinguishable, slow signatures. When drift is recognized, a *sensor alarm* is reported and the apparent leak flow is determined.

This boosts the reliability and the robustness of the system without compromising sensitivity and accuracy. False alarms are prevented, even with low alarm thresholds.

13.3 Leak Location

PipePatrol E-RTTM locates leaks using two methods, both introduced in Chapter 10:

- Model-based gradient intersection method
- Model-based time-of-flight method

The *model-based gradient intersection method* ([Billmann]) calculates an estimate \hat{s}_{Leak} using the amplitudes of the mass residuals x and y at the head stations. The *model-based time-of-flight method* analyses residuals x and y to detect a step. Is a step recognized downstream at time t_{down} in y and recognized upstream at time t_{up} in x , the leak location can be determined by the travel time difference $\Delta t \equiv t_{down} - t_{up}$.

³⁰ Sometimes also called *Virtual Pipeline*.

13.4 PipePatrol E-RTTM/PC – Leak Monitoring in Pumping Conditions

Flow is present during pumping conditions, so flow either as volume flow or mass flow is available. This is also true for *unblocked* paused flow conditions when flow is close to zero.

13.4.1 Head Station Monitoring

This basic scheme applies the RTTM flow residual approach (Chapter 11.2).

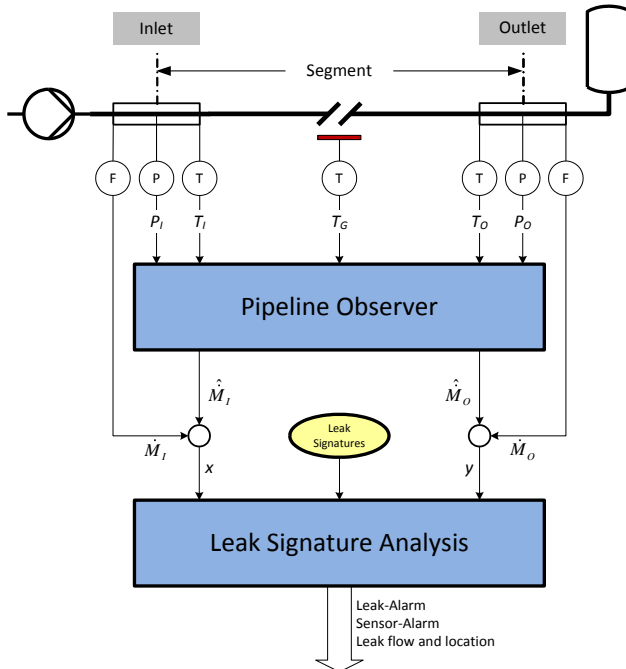

Figure 12: PipePatrol E-RTTM/PC - head station monitoring³¹

The example in Figure 12 shows *head station monitoring* based on the flow residual approach described in Chapter 11.2. With the help of the RTTM, PipePatrol E-RTTM compares the measured flow at inlet and outlet with the calculated flow assuming a leak-free pipeline. The *flow residuals*, which are used by the leak signature analysis, are

$$x \equiv \dot{M}_I - \hat{\dot{M}}_I \quad y \equiv \dot{M}_O - \hat{\dot{M}}_O$$

yielding a leak flow estimate [Billmann]

$$\hat{\dot{M}}_{Leak} = x - y$$

where change of pipeline inventory is implicitly considered. Use of the RTTM pipeline observer therefore compensates for transient behavior of the pipeline. Even in heavily transient conditions (for example during pipeline start-up) x , y and $\hat{\dot{M}}_{Leak}$ stay close to zero in leak-free conditions. Sensitive leak detection is therefore possible in transient conditions.

The dynamic-free residuals are now passed to the second stage, the *leak signature analysis*. Its tasks according to Chapters 13.2 and 13.3 are to:

- Manage alarms
- Determine leak rate and leak location

If pressure and/or temperature sensors fail, the pipeline observer in Figure 12 cannot continue to calculate; in that case, PipePatrol SLB Chapter 12.1.2 serve as a backup LDS but with reduced sensitivity and without leak localization.

³¹ If necessary, the transformation of the volume flow to mass flow is done within PipePatrol – see Chapter 13.4.5.

13.4.2 Substation Monitoring without Flow Measurement

Using the pressure residual method Chapter 11.3 allows for handling substations with pressure measurements as shown below.

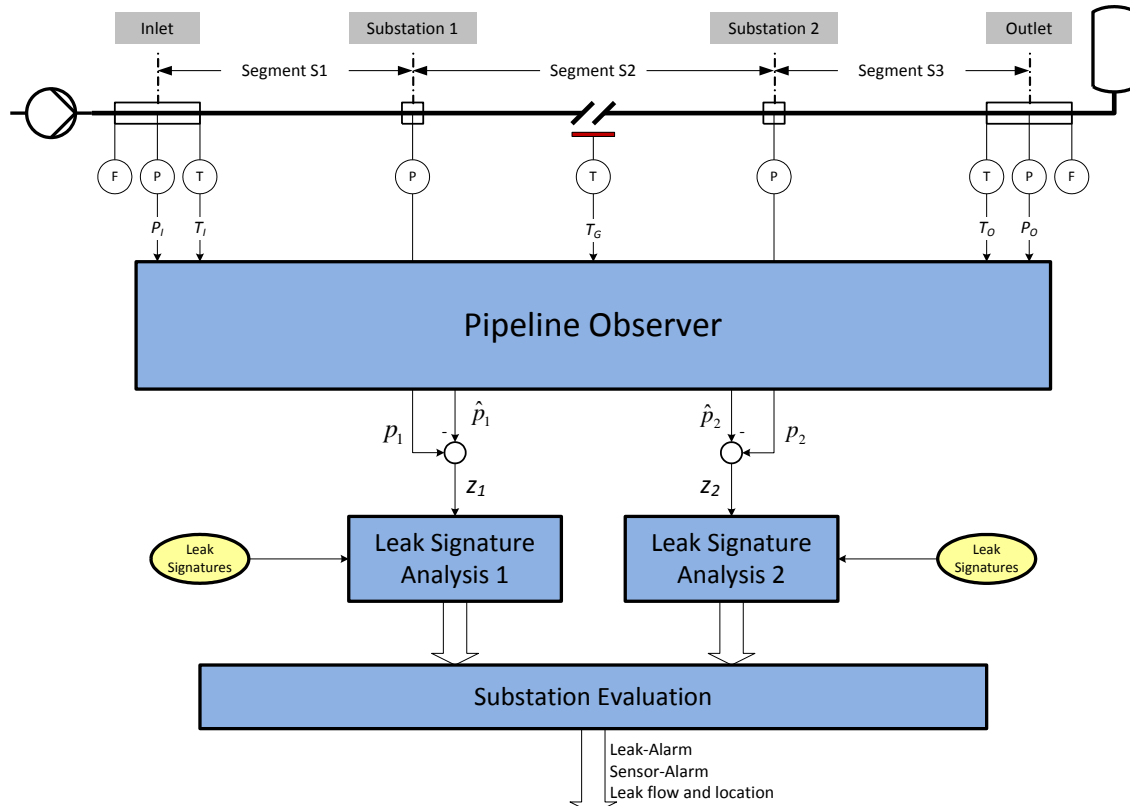

Figure 13: PipePatrol E-RTTM/PC - substations monitoring³²

The RTTM pipeline observer uses pressure and temperature sensors at the head stations to calculate the local profiles, including the pressure profile along the pipe. Any discrepancy between the calculated and the observed pressure at the substations indicates a change in the pipeline dynamics: in other words, a leak. The *pressure residual* at each station is:

$$z_i = p_i - \hat{p}_i, \quad 1 \leq i \leq n$$

These are used by the leak signature analysis to detect a leak and find its location. This kind of pipeline monitoring is called *substation monitoring*. The pipeline observer compensates for any transient behavior of the pipeline.

The compensated residuals are now passed to the second stage, the *leak signature analysis*. Its task is to manage alarms for each individual substation. Results of leak signature analysis are combined by *substation evaluation*, which groups substation alarms and determines leak flow rate and location.

Usually, head station monitoring (Figure 12) and substation monitoring (Figure 13) will be combined to provide leak monitoring for pipeline sections consisting of a number of segments formed by head stations and substations.

³² Two substations are shown for clarity, but the method is able to handle any number of substations.

13.4.3 Sectional Monitoring for Substations with Flow Measurement

The example in Figure 14 shows a pipeline section consisting of two substations with flow measurement.

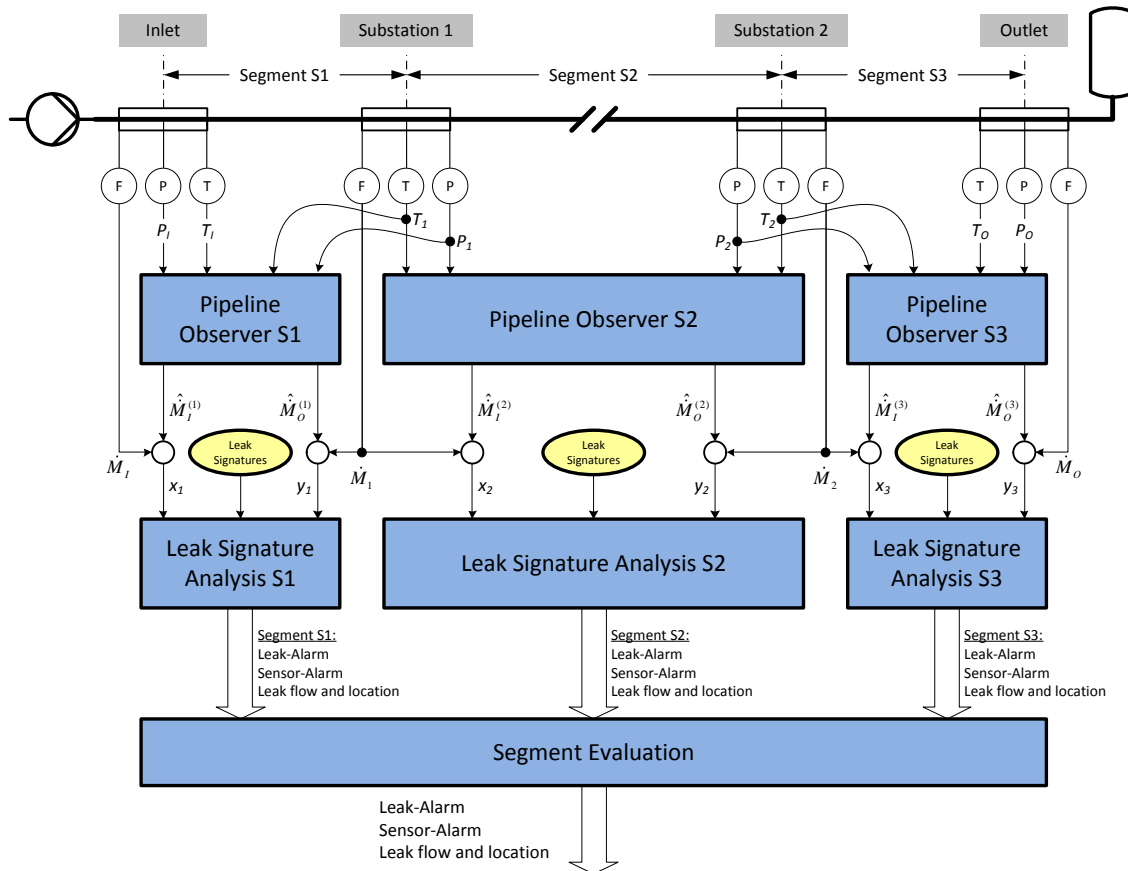

Figure 14: PipePatrol E-RTTM/PC - sectional monitoring, substations fully instrumented³³

Where flow measurement is available at substations in addition to pressure and temperature, the pipeline can be divided into independent segments as shown in the diagram. Independent RTTM pipeline observers and E-RTTM Leak Classifiers may be applied in parallel to every segment, each using the methods already introduced in earlier sections. The shorter length of the monitored sections compared to the overall length of the pipeline leads to several advantages:

- Significantly lower smallest detectable leak rate
- Significantly shorter time to detect a leak
- Significant improvement in accuracy of leak location

The *segment evaluation* chooses the segment that shows the most significant leak signature, determines whether a leak alarm or a sensor alarm is present, and reports the leak location and flow if appropriate.

This method achieves better performance than the method shown in Figure 13, especially on gas pipelines. The disadvantage is the complex instrumentation needed at the substations.

KROHNE Oil and Gas is able to configure this method to assign pipeline segments dynamically. For example, in the event of a transmitter failure at substation 1 it is possible to skip this station and perform leak detection between the inlet station and substation 2.

13.4.4 Sectional Monitoring for Substations without Flow Measurement

The disadvantage of the complex and expensive instrumentation from chapter 13.4.3 can be eliminated by *virtual flow measurement*, as shown in Figure 15.

³³ Two substations are shown for clarity, but the method is able to handle any number of substations. If necessary, the transformation of volume flow to mass flow is done within PipePatrol – see Chapter 13.4.5. Ground temperature is omitted for clarity.

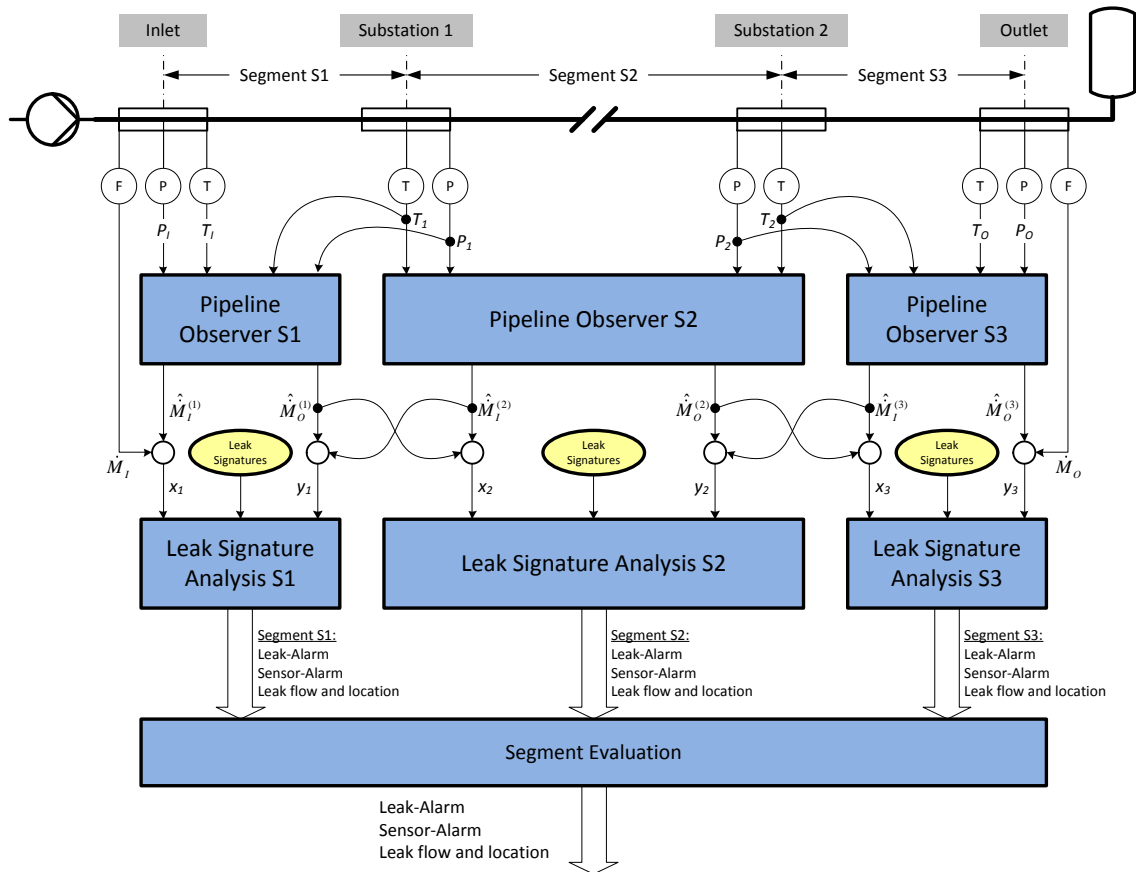

Figure 15: PipePatrol E-RTTM/PC - sectional monitoring, substations without flow measurement³⁴

The functionality is nearly the same as shown in Figure 14, except that direct flow measurement is replaced by values calculated in the RTTM pipeline observer from a neighboring segment.

Each RTTM pipeline observer calculates flow at every point along its associated segment, including the inlet and the outlet. The measured flow at the head stations is compared with the calculated flow in the usual way. At intermediate stations, the calculated outlet flow for the segment upstream is simply compared with the calculated inlet flow for the segment downstream, and vice versa. As only one RTTM pipeline observer calculates the flow at the head stations, a real flow measurement is still needed at these locations for comparison.

If temperature measurements at substations are not present, calculated fluid temperatures from a neighboring segment can be used instead.

13.4.5 Flow Calculation

PipePatrol E-RTTM/PC basically requires mass flow as shown in Figure 12, Figure 14 and Figure 15, but it is not always practical to measure the mass flow in and out of the pipeline directly – for example, direct mass meters are only available in a limited range of sizes. It is also possible to use volumetric flow meters, where usually *flow computers* calculate the mass flow by combining measured volume flow with other measurements. Corresponding flow calculations are standardized.

For special cases, where volumetric flow meters are used but flow computers are not available for conversion from volume flow to mass flow, PipePatrol is able to perform the required calculations internally, e.g. using [API MPMS11].

13.5 PipePatrol E-RTTM/SC – Leak Monitoring in Shut-in Conditions

PipePatrol E-RTTM/PC presented in Chapter 13.4 is limited to pumping conditions where non-zero flow is present or *unblocked* paused flow conditions where flow is close to zero. If valves are used to block the flow, the pipeline

³⁴ Two substations are shown for clarity, but the method is able to handle any number of substations. If necessary, the transformation of volume flow to mass flow is done within PipePatrol – see Chapter 13.4.5. Ground temperature is omitted for clarity. Temperature measurement for substations can be replaced by ground temperature measurement in most cases.

is in *shut-in* or *blocked-line* operation, see Chapter 9; in this case, PipePatrol E-RTTM/SC should be used instead. PipePatrol E-RTTM/SC is a *model-based pressure-temperature method*, which is valid for both liquid and gas pipelines. The relevant valves must be leak-tight, and this should be considered when choosing them.

13.5.1 Head Stations Monitoring

This basic scheme applies the RTTM pressure residual approach Chapter 11.3.

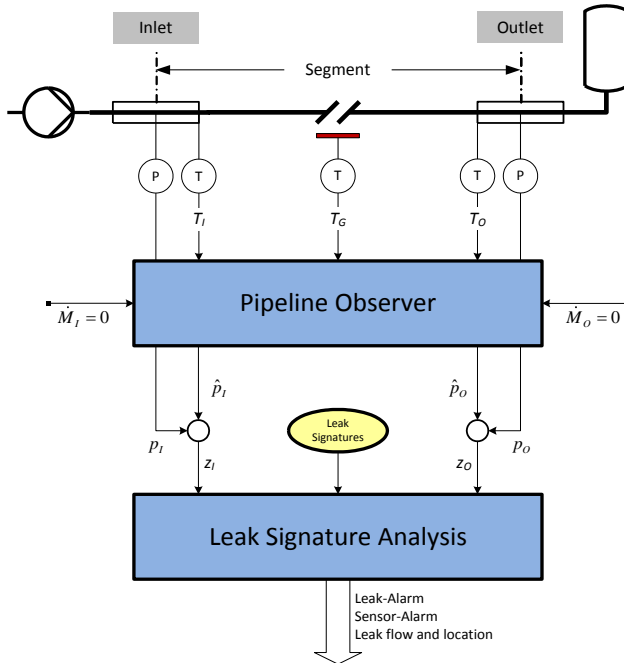

Figure 16: PipePatrol E-RTTM/SC - head station monitoring

It is clear without measurement that the flow at the inlet and outlet should be zero. The RTTM pipeline observer can use this to calculate the local profiles, including the expected pressure at the two head stations. It is possible to compare these with the measured values, giving *pressure residuals* z_I and z_O :

$$z_I \equiv p_I - \hat{p}_I \quad z_O \equiv p_O - \hat{p}_O$$

The RTTM pipeline observer is able to compensate transient behavior of the pipeline in shut-in conditions. In addition, the thermodynamic equation of state in the RTTM compensates for the effect of temperature changes on pressure.

The compensated residuals are passed to the E-RTTM leak signature analysis, as introduced in Chapter 13.2. Leak rate and leak location will be determined when necessary.

13.5.2 Substations Monitoring

Substation monitoring for shut-in is similar to substation monitoring for pumping conditions. Details can be found in Chapter 13.4.2.

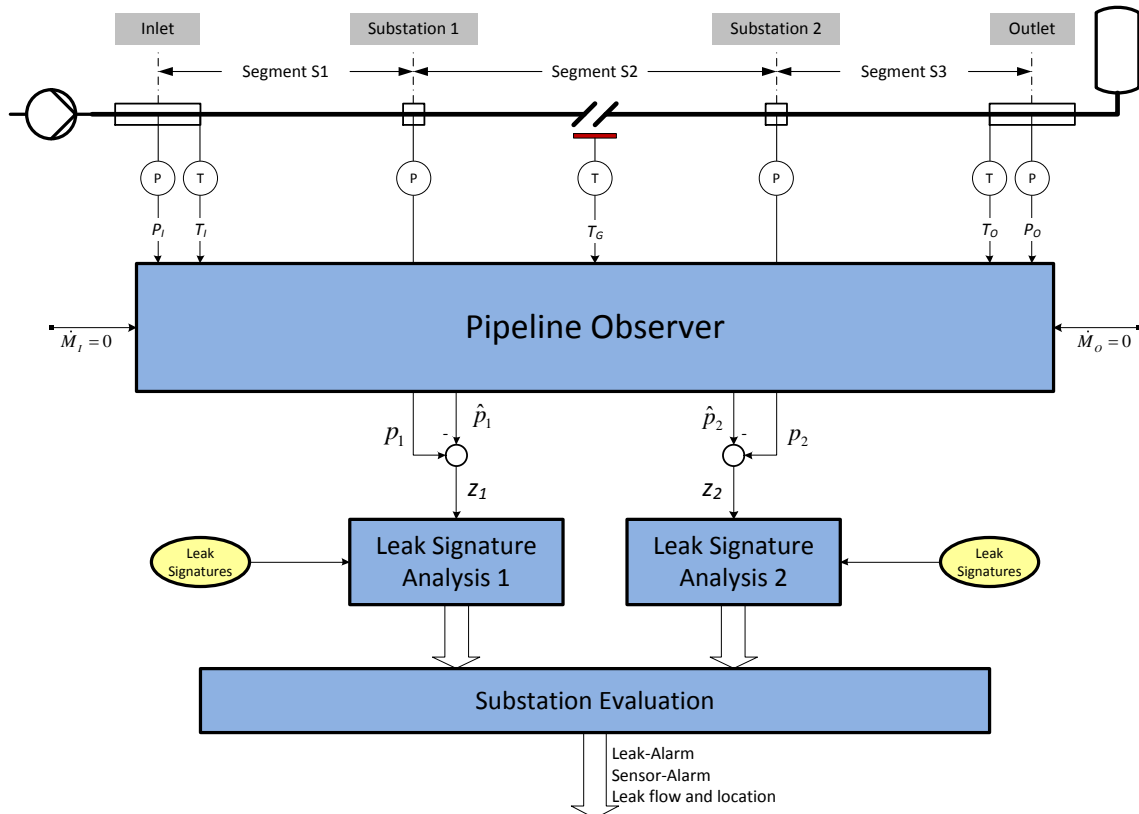

Figure 17: PipePatrol E-RTTM/SC - substations monitoring³⁵

The pressure profile for the entire pipe is calculated using one pipeline observer. Calculated pressures can then be compared with measured values at the substations.

If the relevant valves are completely leak tight, even very small, gradual leaks will be recognized. In this case, PipePatrol E-RTTM/SC meets the requirements of TRFL d).

Usually, head station monitoring (Figure 16) and substation monitoring (Figure 17) will be combined to provide leak monitoring for sections consisting of a number of segments formed by head stations and substations.

³⁵ Two substations are shown for clarity, but the method is able to handle any number of substations.

13.6 Summary

This section summarizes the key requirements and characteristics of the methods introduced in this Chapter. See Chapter 14 for a comparison of all methods covered by this survey.

13.6.1 Functionality and Instrumentation

Method	Function	Instrumentation		
		Complexity	Requirements Static	Dynamic
PipePatrol E-RTTM, Krohne Oil & Gas				
PipePatrol E-RTTM/PC Head Stations Monitoring	LD + LL	2 x (Q,P,T); T _G	Repeatability	Fast
PipePatrol E-RTTM/PC Substation Monitoring	LD + LL	2 x (P,T); T _G n x P	Repeatability	Fast
PipePatrol E-RTTM/PC Sectional Monitoring	LD + LL	2 x (Q,P,T); T _G n x (Q,P,T)	Repeatability	Fast
PipePatrol E-RTTM/PC Sectional Monitoring Virtual Flow	LD + LL	2 x (Q,P,T); T _G n x (P,T)	Repeatability	Fast
PipePatrol E-RTTM/SC Head Stations Monitoring	LD + LL	2 x (P,T); T _G	Repeatability	Fast
PipePatrol E-RTTM/SC Substation Monitoring	LD + LL	2 x (P,T); T _G n x P	Repeatability	Fast

Table 21: Functionality and instrumentation of PipePatrol E-RTTM³⁶

PipePatrol-E-RTTM provides leak detection and leak location in both pumping and shut-in conditions (for details of leak localization see Chapter 10.) PipePatrol E-RTTM/PC Head station monitoring requires measurements of flow, pressure and temperature at the head stations. If ground temperature is reasonably constant along an underground pipeline, a single representative measurement at some point along the pipeline is sufficient. Flow meters at substations are not necessary, but substations must be equipped with pressure sensors. Sectional monitoring requires flow, pressure and temperature for the substations, but using virtual flow technology requirements for the substations can be reduced to pressure and temperature or even pressure alone.

PipePatrol E-RTTM/SC Head station monitoring needs measurements of pressure and temperature at the head stations. Again, ground temperature at some point along the pipeline is sufficient. For Substation monitoring, substations must be equipped with pressure sensors.

PipePatrol E-RTTM uses leak signature analysis; instrument repeatability, rather than accuracy, is therefore the main concern, which reduces the requirements. Instrumentation must be fast (low settling time) in order to follow transient effects correctly.

³⁶ LD = Leak Detection, LL = Leak Location, Q = Flow sensor, T = Temperature sensor, P = Pressure sensor, T_G = Ground temperature sensor

13.6.2 Fields of Application

Method	Application		Medium	TRFL
	Pumping	Dynamics		
PipePatrol E-RTTM, Krohne Oil & Gas				
PipePatrol E-RTTM/PC Head Stations Monitoring	PC	Steady + Transient	Liquids + Gases	a), b), e)
PipePatrol E-RTTM/PC Substation Monitoring	PC	Steady + Transient	Liquids + Gases	a), b), e)
PipePatrol E-RTTM/PC Sectional Monitoring	PC	Steady + Transient	Liquids + Gases	a), b), e)
PipePatrol E-RTTM/PC Sectional Monitoring Virtual Flow	PC	Steady + Transient	Liquids + Gases	a), b), e)
PipePatrol E-RTTM/SC Head Stations Monitoring	SC	Steady + Low Transient	Liquids + Gases	c), d), e)
PipePatrol E-RTTM/SC Substation Monitoring	SC	Steady + Low Transient	Liquids + Gases	c), d), e)

Table 22: Fields of application of PipePatrol E-RTTM³⁷

PipePatrol E-RTTM/PC provides leak detection in pumping conditions; PipePatrol E-RTTM/SC provides leak detection in shut-in conditions. All configurations are able to monitor in steady and (moderately) transient states. Even gas pipelines can be monitored without problems. PipePatrol E-RTTM/PC performs the following functions:

- TRFL a), a continuously functioning system, which can detect leaks in steady state conditions
- TRFL b), a continuous working system which is able to detect leaks in transient state
- TRFL e), a system or procedure to detect the leak position

PipePatrol E-RTTM/SC performs the following functions:

- TRFL c), a system to detect leaks in shut-in conditions
- TRFL d), a system or procedure to detect gradual leaks
- TRFL e), a system or procedure to detect the leak position

13.6.3 Performance Parameters

Method	Sensitivity			Leak Types
	Alarm Threshold	Time to Detect		
		Liquid	Gas	
PipePatrol E-RTTM, Krohne Oil & Gas				
PipePatrol E-RTTM/PC Head Stations Monitoring	Low	Very Short	Medium	Sudden + Graduate
PipePatrol E-RTTM/PC Substation Monitoring	Low	Very Short	Short	Sudden + Graduate
PipePatrol E-RTTM/PC Sectional Monitoring	Low	Very Short	Short	Sudden + Graduate
PipePatrol E-RTTM/PC Sectional Monitoring Virtual Flow	Low	Very Short	Short	Sudden + Graduate
PipePatrol E-RTTM/SC Head Stations Monitoring	Low TRFL c) Very Low TRFL d)	Short TRFL c) Long TRFL d)	Long TRFL c) Very Long TRFL d)	Sudden + Graduate
PipePatrol E-RTTM/SC Substation Monitoring	Low TRFL c) Very Low TRFL d)	Short TRFL c) Long TRFL d)	Long TRFL c) Very Long TRFL d)	Sudden + Graduate

Table 23: Performance parameters of PipePatrol E-RTTM

All configurations of PipePatrol-E-RTTM provide a low alarm threshold, and PipePatrol E-RTTM/SC can offer a very low alarm threshold if required. PipePatrol E-RTTM/PC provides very short times to detect a leak for liquid

³⁷ PC = Pumping Conditions, SC = Shut-in Conditions.

pipelines. Time to detect a leak becomes longer for gas pipelines because of the dynamic inertia of the fluid. All configurations of PipePatrol-E-RTTM are able to detect and locate sudden leaks as well as gradual leaks of sufficient size.

14 Comparison of All Methods

This chapter compares all methods presented so far:

- Chapter 5: Pressure/Flow Monitoring
- Chapter 6: Rarefaction Wave Method
- Chapter 7: Balancing Methods
- Chapter 8: Statistical Leak Detection Systems
- Chapter 9: Leak Monitoring during Shut-In Conditions

The PipePatrol LDS family from KROHNE Oil & Gas is also included in the comparison, namely:

- Chapter 12: PipePatrol Statistical Line Balance (SLB)
- Chapter 13: PipePatrol Extended Real-Time Transient Model (E-RTTM)

This comparison may help interested readers to select the LDS principle best suited to a particular application. Characteristics are listed on an informative basis, and while they are to some extent subjective by nature every effort has been made to present objective facts. For all these methods, typical characteristics are given under the following headings.

14.1 Functionality and Instrumentation

A method may provide leak detection (LD), leak localization (LL), or both (LD+LL). Instrument requirements are indicated as follows:

Static Behavior: "Repeatability" means that repeatability is of primary interest in contrast to "Accuracy" where absolute accuracy is also required. "Repeatability" is less strict (and therefore less expensive) than "Accuracy", see Chapter 3.1.

Dynamic Behavior: "None" (no special requirements for settling time T_S); "Fast" (T_S typically below 1s); "Very Fast" (T_S typically below 0.1s) . For details refer to Chapter 3.1.3.

14.2 Field of Application

This indicates allowed operational conditions ("PC" = Pumping Conditions, "SC" = Shut-in Conditions, "Steady" = Steady State, "Transient" = Transient State). "Low Transient" means that only small transient effects are allowed for correct operation, which normally excludes start-up and shutdown. Allowed fluids are "Liquid", "Gases", and "Liquid + Gases". Please refer to Chapter 2.1 for details of compliance to TRFL: "a)", "b)", "c)", "d)", and "e)".

14.3 Performance Parameters

Alarm thresholds are classified as "High" (typically 5% leak rate or more), "Medium" (typically between 1% and 5%), "Low" (typically around 1%) and "Very Low" (significant lower than 1%).

Time to detect is classified as "Very Long" (half a day or more), "Long" (typically longer than one hour but not more than half a day), "Medium" (typically between ten minutes and one hour), "Fast" (typically between one minute and ten minutes), and "Very Fast" (less than one minute).

Detectable leak types include "Sudden", "Gradual", and "Sudden + Gradual".

Method	Function	Instrumentation			Application Pumping	Medium	TRFL	Sensitivity			Leak Types	
		Complexity	Requirements Static	Dynamic				Alarm Threshold	Time to Detect Liquid	Gas		
Pressure/Flow Monitoring												
Pressure Monitoring	LD	1 x P	Accuracy	None	PC, SC	Steady	Liquids + Gases	a), c)	High	Short	Long	Sudden + Graduate
Flow Monitoring	LD	1 x Q	Accuracy	None	PC	Steady	Liquids + Gases	a)	High	Short	Long	Sudden + Graduate
Rarefaction Wave (Negative Pressure Wave)												
Rarefaction Wave	LD + LL	2 x P	Repeatability	Very fast	PC, SC	Steady	Liquids	a), c), e)	High	Very Short	N/A	Sudden
Balancing Methods												
Mass Balance uncompensated	LD	2 x Q	Accuracy	None	PC	Steady	Liquids	a)	Medium	Long	N/A	Sudden + Graduate
Mass Balance compensated Direct p and T measurement	LD	2 x (Q,P,T) n x (P,T)	Accuracy	None	PC	Steady + Low Transient	Liquids + Gases	a)	Medium	Medium	Long	Sudden + Graduate
Mass Balance compensated Steady state model	LD	2 x (Q,P,T); T _G	Accuracy	None	PC	Steady + Low Transient	Liquids + Gases	a)	Medium	Medium	Medium	Sudden + Graduate
Mass Balance compensated RTTM	LD	2 x (Q,P,T); T _G	Accuracy	Fast	PC	Steady + Transient	Liquids + Gases	a), b)	Medium	Short	Short	Sudden + Graduate
Volume Balance	LD	2 x Q	Repeatability	None	PC	Steady	Liquids	a)	Medium	Long	N/A	Sudden + Graduate
Statistical LDS												
Mass Balance uncompensated Hypothesis Testing	LD	2 x Q	Repeatability	None	PC	Steady + Low Transient	Liquids + Gases	a)	Low	Long	Very Long	Sudden + Graduate
Leak Monitoring during Shut-In Conditions												
PT-Method	LD	2 x (P,T)	Repeatability	None	SC	Steady	Liquids	c), d)	Low TRFL c) Very Low TRFL d)	Very Long	N/A	Sudden + Graduate
DP-Method	LD	n x DP	Repeatability	None	SC	Steady	Liquids	c), d)	Low TRFL c) Very Low TRFL d)	Very Long	N/A	Sudden + Graduate
PipePatrol Statistical Line Balance (SLB), Krohne Oil & Gas												
Mass Balance compensated	LD	2 x (Q,P,T); T _G	Repeatability	Fast	PC	Steady + Transient	Liquids + Gases	a), b)	Low	Short	Medium	Sudden + Graduate
Mass Balance uncompensated	LD	2 x Q	Repeatability	None	PC	Steady + Low Transient	Liquids	a)	Medium	Long	N/A	Sudden + Graduate
Volume Balance	LD	2 x Q	Repeatability	None	PC	Steady + Low Transient	Liquids	a)	Medium	Long	N/A	Sudden + Graduate
PipePatrol E-RTTM, Krohne Oil & Gas												
PipePatrol E-RTTM/PC Head Stations Monitoring	LD + LL	2 x (Q,P,T); T _G	Repeatability	Fast	PC	Steady + Transient	Liquids + Gases	a), b), e)	Low	Very Short	Medium	Sudden + Graduate
PipePatrol E-RTTM/PC Substation Monitoring	LD + LL	2 x (P,T); T _G n x P	Repeatability	Fast	PC	Steady + Transient	Liquids + Gases	a), b), e)	Low	Very Short	Short	Sudden + Graduate
PipePatrol E-RTTM/PC Sectional Monitoring	LD + LL	2 x (Q,P,T); T _G n x (Q,P,T)	Repeatability	Fast	PC	Steady + Transient	Liquids + Gases	a), b), e)	Low	Very Short	Short	Sudden + Graduate
PipePatrol E-RTTM/PC Sectional Monitoring Virtual Flow	LD + LL	2 x (Q,P,T); T _G n x (P,T)	Repeatability	Fast	PC	Steady + Transient	Liquids + Gases	a), b), e)	Low	Very Short	Short	Sudden + Graduate
PipePatrol E-RTTM/SC Head Stations Monitoring	LD + LL	2 x (P,T); T _G	Repeatability	Fast	SC	Steady + Low Transient	Liquids + Gases	c), d), e)	Low TRFL c) Very Low TRFL d)	Short TRFL c) Long TRFL d)	Long TRFL c) Very Long TRFL d)	Sudden + Graduate
PipePatrol E-RTTM/SC Substation Monitoring	LD + LL	2 x (P,T); T _G n x P	Repeatability	Fast	SC	Steady + Low Transient	Liquids + Gases	c), d), e)	Low TRFL c) Very Low TRFL d)	Short TRFL c) Long TRFL d)	Long TRFL c) Very Long TRFL d)	Sudden + Graduate

Legend
 Instrumentation: Q = Flow, P = Pressure, T = Product Temperature, T_G = Ground Temperature, DP = Differential Pressure
 Function: LD = Leak Detection, LL = Leak Localization
 Condition: PC = Pumping Conditions, SC = Shut-in Conditions
 TRFL: a) Continuous steady-state Operation, b) Continuous transient Operation, c) Paused Flow, d) Gradual Leak, e) Leak Localization

2012-03-17

Table 24: Comparison of all methods

A Bibliography

- [ADEC] ADEC: Technical Review of Leak Detection Technologies, Volume 1. Alaska Department of Environmental Conservation, 1999.
- [API RP 1130] API RP 1130: Computational Pipeline Monitoring for Liquid Pipelines. Recommended Practice from the American Petroleum Institute, 2007.
- [API 1149] API 1149: Pipeline Variable Uncertainties and Their Effect on Leak Detectability. American Petroleum Institute, 1993.
- [API 1155] API 1155: Evaluation Methodology for Software Based Leak Detection Systems. American Petroleum Institute, 1995. (Withdrawn by API).
- [API MPMS11] API Manual of Petroleum Measurement Standards Chapter 11: Physical Properties Data. American Petroleum Institute, 2007.
- [Baehr] Baehr, H. D., Kabelac, S.: Thermodynamik. Springer, 14. Auflage, 2009.
- [Barkat] Barkat, M.: Signal Detection and Estimation. Artech House, 1991.
- [Billmann] Billmann, L.: Methoden zur Lecküberwachung und Regelung von Gasfernleitungen. Fortschrittsberichte VDI Reihe 8, VDI-Verlag.
- [Bohl] Bohl, W.: Technische Strömungslehre. Vogel-Verlag, 12. Auflage, 2002.
- [Geiger] Geiger, G.: Leak Detection and Locating – A Survey. 35th Annual PSIG Meeting, 15 October – 17 October 2003, Bern, Switzerland.
- [Kay] Kay, Steven M.: Fundamentals of Statistical Signal Processing, Volume 2. Prentice Hall, 1998.
- [Krass/Kittel/Uhde] Krass, W., Kittel, A., Uhde, A.: Pipelinetechnik. Verlag TÜV Rheinland, 1979.
- [Kroschel] Kroschel, K.: Statistische Nachrichtentheorie. Springer-Verlag, 1996.
- [RFVO] Rohrfernleitungsverordnung. In TRFL - Technische Regeln für Rohrfernleitungsanlagen. Carl-Heymanns-Verlag, 2010.
- [TRFL] TRFL - Technische Regeln für Rohrfernleitungsanlagen. Carl-Heymanns-Verlag, 2010.
- [VdTÜV 1051] VdTÜV 1051: Wasserdruckprüfung von erdverlegten Rohrleitungen nach dem Druck-Temperatur-Messverfahren (D-T-Verfahren). VdTÜV-Merkblatt.
- [Wald] Wald, A.: Sequential Analysis, John Wiley and Sons, New York, 1947.
- [Zhang] Zhang, X. J.: Statistical Leak Detection in Gas and Liquid Pipelines. Pipes & Pipelines International, July – August 1993, p. 26 – 29.

B Definitions

– A –

Accuracy: Within the context of LDS, performance criteria by [API RP 1130]. A measure describing the accuracy of leak flow and position calculation. For measurement systems in general, the degree of closeness of measurements x of a quantity to that quantity's true value x_{true} . See also: Accuracy, Reliability, Repeatability, Robustness, and Sensitivity.

API 1149: "Pipeline Variable Uncertainties and Their Effect on Leak Detectability." Published by the American Petroleum Institute. Allows for the calculation of a theoretical limit to leak detection sensitivity based on instrument accuracy and pipeline characteristics.

API 1155: "Evaluation Methodology for Software Based Leak Detection Systems." Published by the American Petroleum Institute. Defines performance metrics like sensitivity, accuracy, reliability and robustness. Withdrawn. See also: API RP 1130.

API MPMS Chapter 11: "API Manual of Petroleum Measurement Standards Chapter 11: Physical Properties Data." Published by American Petroleum Institute. Describes relations to calculate density of fluids (crude oil, refined products etc.) from temperature and pressure.

API RP 1130: Recommended Practice "Computational Pipeline Monitoring for Liquid Pipelines". Published by the American Petroleum Institute. Gives a technical overview about leak detection technologies, describes infrastructure supports for CPM, and discusses CPM operation, maintenance and testing. Defines performance metrics like sensitivity, accuracy, reliability and robustness (from API 1155). See also: TRFL.

– B –

Batch: A certain quantity of fluid (product) planned for pipeline transport from inlet to outlet. See also: Fluid, Pipeline, Product.

– C –

Communication Protocol: A set of conventions governing the format and timing of data transmission between communication devices, including handshaking, error detection, and error recovery. Synonym: Protocol. See also: Supervisory Control and Data Acquisition (SCADA).

Compensated Mass Balance: Mass balance method which compensates for change of mass inventory in a pipeline. See also: Line Balance, Mass Balance, Uncompensated Mass Balance, and Volume Balance.

Compressibility: Attribute of a fluid, representing the rate of change of density with respect to pressure and temperature. It is compensated by (E)-RTTM-Systems.

Conservation of Mass: Physical law that states that mass transported by a pipeline will be conserved in case that there is no leak. See also: Mass Balance.

Coriolis Mass Meter: Flow-measuring device directly measuring mass flow basing on the Coriolis principle. See also: Flow meter, Orifice Plate, Positive Displacement Meter, Turbine Meter, Ultrasonic Meter, and Volumetric Flow Meter.

– C (Continued) –

CPM System: Computational pipeline monitoring system according to [API RP 1130]. Synonym for software-based LDS. See also: Leak Detection System (LDS).

– D –

Data Acquisition (DAQ): The process of acquiring analogue field data and converting them into digital values. The quality of this process is mainly specified by the resolution given in bits. See also: Resolution, Supervisory Control and Data Acquisition (SCADA).

Data Communication Equipment (DCE): Equipment that provides the functions required to establish, maintain, or terminate a connection and the signal conversion and coding required for communication between data terminal equipment and data circuits. Examples include modems, line drivers, coaxial cable, satellite links, etc. See also: Supervisory Control and Data Acquisition (SCADA).

Density Meter: A sensor that monitors the actual density of a fluid. See also: Flow meter.

Detection Limit: Synonym: Leak Detection Limit.

Differential-Pressure Method (DP Method): Differential pressure across a tightly closed valve between two tightly closed segments is analyzed. See also: Pressure-Temperature Method (PT Method).

Digital Data Service (DDS): A special wide-bandwidth private leased line (PLL) that uses digital techniques to transfer data at higher speeds and lower error rate than voice-band, analog PLLs. See also: Private Leased Line (PLL), Public Switched Telephone Network (PSTN). See also: Supervisory Control and Data Acquisition (SCADA).

Drag Reducing Agent (DRA): Added to liquids to reduce pipe wall friction.

Drift: Synonym: Measurement Drift!

– E –

EOS: Equation of State. Synonyms: PVT-Equation, Thermodynamic Equation of State.

External LDS: According to [API RP 1130], LDSs using dedicated measurement equipment such as sensing cables (e.g. vapor tube, fiber optic cables). PipePatrol E-RTTM LDS and PipePatrol SLB LDS *do not* belong to that LDS family. See also: Internal LDS.

E-RTTM LDS: LDS based on Extended RTTM-technology. This technology combines RTTM-technology with the leak signature analysis. See also: Real-Time Transient Model (RTTM), RTTM-LDS, Leak Signature Analysis, PipePatrol E-RTTM LDS.

– F –

False Alarm: A leak alarm that is raised when no real leak is present. False alarm probability P_{FA} specifies the expected number of false alarms, e.g. per year. See also: Leak Alarm, Missed Alarm.

– F (Continued) –

Flow: Collective term for mass flow (e.g. in kg/s), volume flow (e.g. in m³/h), and velocity (e.g. in m/s).

Flow meter: Device measuring volume and/or mass flow. See also: Coriolis Mass Meter, Orifice Plate, Positive Displacement Meter, Turbine Meter, Ultrasonic Meter, and Volumetric Flow meter.

Flow Computer: Device used to “pre-process” flow field signals e.g. by calculating mass flow from volume flow for volumetric flow meters. See also: Flow meter, Volumetric flow meter.

Flow Monitoring: A simple leak detection method where flow is measured at a single location in the pipeline; flow changes in case of a leak. See also: Pressure Monitoring.

Flow Residual: Difference between measured flow and the value calculated by pipeline observer assuming a leak-free pipeline. Used by PipePatrol E-RTTM/PC. See also: Pipeline Observer, Pressure Residual, Residual, and PipePatrol E-RTTM/PC.

Fluid: A substance that is capable of flowing through a pipeline, including all gases and liquids. See also: Batch, Product.

Full-Duplex Protocol: A mode of operation for a point-to-point link with two stations, in which messages can be sent in both directions at the same time. See also: Half-Duplex Protocol, Supervisory Control and Data Acquisition (SCADA).

– G –

Gaussian (Normal) Distribution: Well-known form of probability density function, first published by Gauss. Also called normal distribution. Very often used for the underlying statistical methods of Statistical LDS. See also: Statistical LDS.

Gradient-Intersection Method: Method of leak location based on characteristic changes in pressure profile along the pipeline. PipePatrol E-RTTM uses a model-based version, which is able to locate a leak even in transient conditions. See also: Leak Localization, Time-Of-Flight Method.

Gradual Leak: A slowly developing leak identifiable by a drift signature, often with a very low leak flow. [TRFL] demands dedicated LDS to detect gradual leaks. PipePatrol E-RTTM raises sensor alarm for gradual leaks of sufficient size. See also: Sensor Alarm, Sudden Leak.

– H –

Half-Duplex Protocol: A mode of operation for a point-to-point or point-to-multipoint link with two stations, in which messages can be sent in one direction or the other but not both at the same time. See also: Full-Duplex Protocol, Supervisory Control and Data Acquisition (SCADA).

Head Station: Measuring station at the pipeline inlet or outlet. See also: Measuring Station, Substation.

Head Station Monitoring: This configuration of PipePatrol E-RTTM uses measurements from the head stations of a pipeline to calculate the flow-residuals and monitor the pipeline for leaks. See also: PipePatrol E-RTTM LDS, Sectional Monitoring, and Substations Monitoring.

– H (Continued) –

Hypothesis Test: Family of method from statistical decision theory, often used by Statistical LDS.

Examples are likelihood-ratio test and sequential probability-ratio test. See also: Likelihood-Ratio Test, Sequential Probability-Ratio Test, and Statistical LDS.

– I –

Imbalance: Difference between mass (or volume) entering a pipeline and mass (or volume) leaving it, observed over some time period Δt . Change of mass inventory may additionally be considered. See also: Mass Balance.

Inlet: The point where the fluid enters the pipeline in forward operation. See also: Outlet.

Internal LDS: According to [API RP 1130], LDSs that use existing measurement sensors for flow, pressure, temperature etc. PipePatrol E-RTTM LDS and PipePatrol SLB LDS belong to that LDS family. See also: External LDS.

Inventory: Synonym: Pipeline Inventory.

Inventory Compensation: Synonym: Pipeline Inventory Compensation.

– K –

KROHNE Oil & Gas: Netherlands subsidiary of KROHNE Messtechnik Duisburg GmbH & Co. KG. PipePatrol is the LDS-Family of KROHNE Oil & Gas. See also: PipePatrol LDS.

– L –

Leak Alarm: Declaration of a leak event. PipePatrol E-RTTM LDS will raise this type of alarm in case of a sudden leak. See also: PipePatrol E-RTTM LDS, Sudden Leak.

Leak Detection: Process of deciding if there is a leak or not. Usually LDS are used for this purpose. See also: Leak Detection System (LDS), Leak Localization, and Leak Monitoring.

Leak Detection Limit: Theoretical value of the smallest detectable leak flow or rate. Synonym: Detection Limit. See also: Leak Flow, Leak Rate.

Leak Detection System (LDS): An internal or external based system to detect leaks in pipelines, which may also calculate leak location. In Germany, LDS must meet the requirements of the [TRFL]. See also: CPM System, Leak Detection, and Leak Localization.

Leak Flow: Mass or volume flow of the leak. See also: Leak Rate.

Leak Localization: Process of determining the position of a leak, commonly calculated by an LDS. See also: Leak Detection, Leak Detection System (LDS), Leak Monitoring.

Leak Monitoring: Monitoring process involving leak detection and leak localization. See also: Leak Detection, Leak Localization.

– L (Continued) –

Leak Rate: Leak flow related to a reference value, e.g. nominal flow of the pipeline. See also: Leak Flow.

Leak Signature: Specific signature in signals which occurs in case of a leak, e.g. step (for sudden leaks) or drift (for gradual leaks). See also: Leak Signature Analysis.

Leak Signature Analysis: Method used by PipePatrol E-RTTM to avoid false alarms where residuals are analyzed for leak signatures. In case of a leak, a leak alarm (for a sudden leak) or sensor alarm (for a gradual leak or measurement drift and offset) is raised. See also: E-RTTM LDS, Leak Alarm, Leak Signature, Sensor Alarm, PipePatrol E-RTTM LDS.

Likelihood-Ratio Test: Statistical method to decide between two predefined hypotheses (e.g. leak no/yes) based on a set of measured values. Some statistical LDS use this principle for leak detection. The sequential version is called sequential probability-ratio test. See also: Hypothesis Test, Sequential Probability-Ratio Test, and Statistical LDS.

Line Balance: Generic term covering all balancing methods (mass balance and volume balance). See also: Mass Balance, Compensated Mass Balance, Uncompensated Mass Balance, and Volume Balance.

Local Profiles: Flow and thermodynamic values such as mass flow, pressure, temperature and density, calculated for every point along the pipeline.

– M –

Mass Balance: Methods that use the conservation of mass principle for leak detection. Synonym: Material Balance. See also: Imbalance, Line Balance, Compensated Mass Balance, Uncompensated Mass Balance, and Volume Balance.

Master Station (MS): A SCADA device such as a PLC with I/O modules that sends data to and collects data from remote stations. See also: Programmable Logic Controller (PLC), Remote Station (RS), and Supervisory Control and Data Acquisition (SCADA).

Material Balance: Synonym: Mass Balance.

Measurement Drift: Very low frequency error in measurements. PipePatrol E-RTTM raises sensor alarm for measurement drift (flow, pressure, temperature) of sufficient size. Synonym: Drift. See also: Measurement Error, Measurement Offset.

Measurement Error: Deviation $E \equiv x - x_{true}$ between an actual measurement x and the unknown true value x_{true} is called *absolute* measurement error. If divided by some reference value x_{ref} (e.g. x_{true} or measurement range $x_{max} - x_{min}$), it is called *relative* measurement error. See also: Measurement Drift, Measurement Offset.

Measurement Offset: Constant error in measurements. PipePatrol E-RTTM raises sensor alarm for measurement offsets (flow, pressure, temperature) of sufficient sizes. Synonym: Offset. See also: Measurement Drift, Measurement Error.

– M (Continued) –

Measurement Station: A station at one specific point of the pipeline, equipped with sensors and SCADA devices. At inlet and outlet they are called head stations, otherwise substations. See also: Head Station, Substation, and Supervisory Control and Data Acquisition (SCADA).

Missed Alarm: A failure to declare an alarm when there is a real leak. Missed alarm probability P_{MA} specifies the expected number of missed alarms, e.g. per year. See also: False Alarm, Leak Alarm.

Modbus: A serial communications protocol first published in 1979 for use with its programmable logic controllers (PLCs). One of the de facto standard communications protocols in the industry. See also: OLE For Process Control (OPC), Supervisory Control and Data Acquisition (SCADA).

Multi-Product Pipeline: Pipeline that transport several different products. See also: Single-Product Pipeline.

Multipoint-To-Multipoint: Communication link between three or more stations where there is no communication arbitrator (master) and any station can initiate communications with any other station. See also: Point-to-Point, Point-to-Multipoint, and Supervisory Control and Data Acquisition (SCADA).

– N –

Nominal Flow: Flow at nominal conditions, e.g. in m^3/h .

– O –

Offset: Synonym: Measurement Offset.

OLE For Process Control (OPC): Communication standard specifying the communication of real-time plant data between control devices from different manufacturers. See also: Modbus, Supervisory Control and Data Acquisition (SCADA).

Orifice Plate: Differential pressure-generating flow metering device. Orifice plates are not directly either mass or volumetric flow meters. See also: Coriolis Mass Meter, Flow meter, Orifice Plate, Positive Displacement Meter, Turbine Meter, Ultrasonic Meter, and Volumetric Flow meter.

Outlet: The end of a pipeline where the fluid leaves in forward operation. See also: Inlet.

– P –

Paused Flow Conditions: Conditions where no fluid is pumped through the pipeline. Flow may be unblocked or blocked (shut-in conditions) by valves. [TRFL] assumes special LDS for these conditions. See also: Pumping Conditions, Shut-in Conditions.

Pipeline: A long-distance line for fluid (product) transport. See also: Fluid, Product.

Pipeline Controller: A person who is responsible for the monitoring and direct control of a pipeline. Synonym: Pipeline Operator.

– P (Continued) –

Pipeline Inventory: Mass stored within a pipeline segment. Synonym: Inventory. See also: Pipeline Inventory Compensation.

Pipeline Inventory Compensation: Method to compensate for changes of pipeline contents in mass balance. PipePatrol SLB optionally applies RTTM based compensation. Synonym: Inventory Compensation. See also: Mass Balance, Pipeline Inventory, and PipePatrol Statistical Line Balance (SLB) LDS.

Pipeline Observer: SW-Module within PipePatrol E-RTTM (and SLB), which calculates residuals based on measured values. It is used to eliminate compressibility and elasticity effects. It may also be used for virtual flow calculation. Synonym: Virtual Pipeline. See also: Leak Signature Analysis, PipePatrol E-RTTM LDS, PipePatrol Statistical Line Balance (SLB) LDS, and Virtual Flow.

Pipeline Operator: Synonym: Pipeline Controller.

Pipeline Rupture: Occurs when there is a significant breach of the pipe wall or major loss of containment of the product within the pipeline. May lead to a large, sudden leak flow. Synonym: Rupture.

Pipeline Section: A subdivision of a complete pipeline network, which may consist of one or more pipeline segments. See also: Pipeline Segment. Synonym: Section.

Pipeline Segment: A single connection between two nodes in a pipeline net. In general a subdivision of a pipeline section. Synonym: Segment. See also: Pipeline Section.

PipePatrol E-RTTM LDS: PipePatrol Extended Real-Time Transient Model LDS by KROHNE Oil & Gas based on E-RTTM-technology (pipeline observer) and leak signature analysis. Provides Leak detection and location in pumping conditions (PipePatrol E-RTTM/PC) and shut-in conditions (PipePatrol E-RTTM/SC) for steady and transient states as defined in [API RP 1130] and [TRFL]. Raises leak alarm for sudden leaks, and sensor alarm for gradual leaks or measurement drift or offsets. Different configurations are available for different pipeline net structures: Head station monitoring, substation monitoring, and sectional monitoring. PipePatrol Statistical Line Balance (SLB) may serve as a backup LDS in case of pressure and/or temperature sensor failure. See also: E-RTTM LDS, Head Stations Monitoring, Leak Alarm, Leak Signature Analysis, Pipeline Observer, PipePatrol Statistical Line Balance (SLB), Sectional Monitoring, Sensor Alarm, and Substations Monitoring.

PipePatrol E-RTTM/PC: Configuration of PipePatrol E-RTTM for pumping conditions. See also: PipePatrol E-RTTM, Pumping Conditions.

PipePatrol E-RTTM/SC: Configuration of PipePatrol E-RTTM for shut-in conditions. See also: PipePatrol E-RTTM, Shut-in Conditions.

PipePatrol LDS: Family of LDS by KROHNE Oil & Gas. At this time consists of PipePatrol E-RTTM LDS and PipePatrol Statistical Line Balance (SLB). See also: KROHNE Oil & Gas, PipePatrol E-RTTM LDS, PipePatrol Statistical Line Balance (SLB) LDS.

– P (Continued) –

PipePatrol Statistical Line Balance (SLB) LDS: LDS by KROHNE Oil & Gas providing leak detection using mass- and volume balance together with RTTM based pipeline inventory compensation (pipeline observer). Different configurations for uncompensated mass balance, compensated mass balance and volume balance are available. May serve as a backup LDS for PipePatrol E-RTTM in case of pressure and/or temperature sensor failure. See also: Line Balance, Pipeline Inventory Compensation, Pipeline Observer, PipePatrol E-RTTM.

Point-to-Multipoint: A network where connections exist between one master station and multiple remote stations. See also: Multipoint-to-Multipoint, Point-to-Point, and Supervisory Control and Data Acquisition (SCADA).

Point-to-Point: A network where a connection is made between two and only two terminal installations. See also: Multipoint-to-Multipoint, Point-to-Multipoint, and Supervisory Control and Data Acquisition (SCADA).

Poll: Procedure where master station sends a message to a remote station that requires the remote station to return a response to the master or another remote station. See also: Supervisory Control and Data Acquisition (SCADA).

Polling Time: Time interval between two consecutive polls on a SCADA communication link. Synonym: Scan Time. See also: Poll, Supervisory Control and Data Acquisition (SCADA).

Positive Displacement Meter: Flow-measuring device that measures flow by moving the liquid through measuring chambers of known volume. Belongs to volumetric flow meters. See also: Coriolis Mass Meter, Flow meter, Orifice Plate, Turbine Meter, Ultrasonic Meter, and Volumetric Flow meter.

Pressure Monitoring: A simple leak detection method where pressure is measured at a single location on the pipeline; pressure drops in case of a leak. See also: Flow Monitoring.

Pressure Residual: Difference between measured pressure and the value calculated by pipeline observer assuming a leak-free pipeline. Used for particular configurations by PipePatrol E-RTTM/PC and generally by PipePatrol E-RTTM/PC. See also: Flow Residual, Pipeline Observer, Residual, and PipePatrol E-RTTM.

Pressure-Temperature Method (PT Method): Pressure within a tightly closed pipeline segment is analyzed, and temperature compensated using an equation of state for the fluid. PipePatrol E-RTTM/SC uses a model-based version of this method. See also: Differential-Pressure Method (DP Method).

Private Leased Line (PLL): A dedicated voice-band telephone line between two or more locations primarily used for data transmission. See also: Digital Data Service (DDS), Public Switched Telephone network (PSTN), and Supervisory Control and Data Acquisition (SCADA).

Probability Density Function (PDF): Function of probability theory, which enables calculation of probability for an event. See also: Gaussian (Normal) Distribution.

Product: A fluid flowing through a pipeline, including all gases and liquids. See also: Batch, Fluid, Pipeline.

– P (Continued) –

Programmable Logic Controller (PLC): Digital computer used for automation. Unlike general-purpose computers, the PLC is designed for multiple input and output arrangements, extended temperature ranges, immunity to electrical noise, and resistance to vibration and impact. May be part of SCADA master stations and remote stations. See also: Master Station (MS), Remote Station (RS), and Supervisory Control and Data Acquisition (SCADA).

Protocol: Synonym: Communication Protocol.

Public Switched Telephone Network (PSTN): The standard dial-up telephone network originally used for voice communication. See also: Digital Data Service (DDS), Private Leased Line (PLL), and Supervisory Control and Data Acquisition (SCADA).

Pumping Conditions: Conditions where fluid is pumped through the pipeline. [TRFL] assumes special LDS for these conditions. See also: Shut-in Conditions, Paused Flow Conditions.

PVT-Equation: Synonyms: EOS, Thermodynamic Equation of State.

– R –

Rarefaction Wave: Hydraulic wave-like effect in case of a leak propagating with speed of sound. See also: Rarefaction Wave Method.

Rarefaction Wave Method: LDS evaluating rarefaction waves created by sudden leaks. See also: Rarefaction Wave.

Real-Time Transient Model (RTTM): Simulation model of flow in pipelines covering the steady state as well as the transient state. Calculated in real time by digital computers. See also: E-RTTM LDS, RTTM LDS.

Reliability: Within the context of LDS, performance criterion defined by [API RP 1130]. Ability of a leak detection system to render accurate decisions about the possible existence of a leak on the pipeline, while operating within an envelope established by the leak detection system design. Directly related to probability of a false alarm and probability of a missed alarm. See also: Accuracy, Robustness, and Sensitivity.

Remote Station (RS): A SCADA device such as a PLC with I/O modules that is located in a site remote from the master station and that controls I/O points at the remote site. A remote station accepts commands from and may send data to a master station via a network. See also: Programmable Logic Controller (PLC), Master Station (MS), Remote Terminal Unit (RTU), and Supervisory Control and Data Acquisition (SCADA).

Remote Terminal Unit (RTU): Remote station only acquiring data. See also: Remote Station (RS), Supervisory Control and Data Acquisition (SCADA).

– R (Continued) –

Repeatability: Closeness of agreement between independent measurement readings obtained with the same measurement system under the same conditions (same flow, same environmental conditions etc.). Very often repeatability is defined as the value below which the absolute difference $|\Delta x| \equiv |x[k] - x[k - 1]|$ between two successive single measurements $x[k]$ and $x[k - 1]$ obtained under the same conditions may be expected to lie with a specified probability (e.g. 95%). See also: Accuracy.

Residual: Difference between a measured value (e.g. pressure or flow) and a corresponding value calculated by pipeline observer assuming a leak-free pipeline. For PipePatrol E-RTTM, input for leak signature analysis. PipePatrol uses flow and pressure residuals depending on the configuration. Residuals are analyzed by leak signature analysis for leak alarm declaration and leak localization. See also: Flow Residuals, Leak Signature Analysis, Pipeline Observer, PipePatrol E-RTTM LDS, and Pressure Residuals.

Resolution: Within the context of data acquisition, the smallest increment of signal change that can be determined by a converter normally specified in bits. See also: Data Acquisition, Supervisory Control and Data Acquisition (SCADA).

Robustness: Within the context of LDS, performance criterion defined by [API RP 1130]. Ability to continue to function and provide useful information even under changing conditions of pipeline operation, or in conditions where data is lost or suspect. A system is considered to be robust if it continues to function under such non-ideal conditions. See also: Accuracy, Reliability, and Sensitivity.

RTTM-LDS: LDS basing on a Real-Time Transient Model (RTTM). See also: E-RTTM LDS, Real-Time Transient Model (RTTM).

Rupture: Synonym: Pipeline Rupture.

– S –

Scan Time: Synonym: Poll Time.

Section: Synonym: Pipeline Section.

Sectional Monitoring: This configuration of PipePatrol E-RTTM splits pipelines into segments bounded by measurement stations (head stations and substations), and monitors each segment independently. Substations may provide flow, pressure and temperature; using the virtual flow method, flow and temperature of a substation may be replaced by values calculated from the pipeline observer. See also: Head Stations Monitoring, Pipeline Observer, PipePatrol E-RTTM LDS, Substations Monitoring, and Virtual Flow.

Segment: Synonym: Pipeline Segment.

Sensitivity: Within the context of an LDS, a performance criterion defined by [API RP 1130]. Composite criterion, combining smallest detectable leak flow as well as time to detect a leak. Example: Lost volume or mass by leak flow from beginning of leak flow till leak alarm. See also: Accuracy, Reliability, and Robustness.

– S (Continued) –

Sensor Alarm: PipePatrol E-RTTM will raise this type of alarm in case of a gradual leak or measurement drift and offset. See also: Gradual Leak, Leak Alarm, PipePatrol E-RTTM LDS.

Sequential Probability-Ratio Test (SPRT): A sequential version of the likelihood-ratio test. Some statistical LDS use this principle for leak detection. See also: Likelihood-Ratio Test, Statistical LDS.

Settling Time: Time required for the response curve of a sensor to reach and stay within a range of certain percentage (usually 5% or 2%) of the final value following a step change in the measured variable.

Shutdown: Transition phase of pipeline operation where operation mode changes from pumping conditions to paused flow conditions. See also: Start-up, Transient State.

Shut-in Conditions: Paused flow conditions, where pumps are switched off, and flow is blocked by valves. See also: Pumping Conditions, Paused Flow Conditions.

Single-Product Pipeline: Pipeline where only one single product is transported. See also: Multi-Product Pipeline.

Slack Line: Conditions where a segment of a liquid pipeline is not entirely filled, sometimes as a result of vaporization of the transported product.

Speed of Sound: Propagation speed of pressure-, density- and flow dynamics in fluids. Leak location by Time-of-Flight Method is based on the speed of sound.

Standard Conditions: Combination of temperature (e.g. 10°C) and pressure (e.g. 1.101325bar) at which fluid standard volumes are expressed.

Start-up: Transition phase of pipeline operation where operation mode changes from paused flow conditions to pumping conditions. See also: Shutdown, Transient State.

Statistical LDS: Family of LDS with a focus on statistical methods. See also: Hypothesis Test, Leak Signature Analysis, Likelihood-Ratio Test, and Sequential Probability-Ratio Test (SPRT).

Statistical Leak Classification: Statistical module within PipePatrol Statistical Line Balance (SLB) for preventing false alarms while maintaining the highest possible sensitivity. See also: PipePatrol Statistical Line Balance (SLB).

Steady State: Process conditions for a pipeline, where physical values (e.g. flow and pressure) do NOT change significantly over time. [TRFL] requires an LDS to be capable of monitoring pipelines for leaks under steady state conditions. See also: Transient State.

Substation: All measurement stations other than the inlet and outlet (which are called head stations). See also: Head Station, Measurement Station.

Substation Monitoring: This configuration of PipePatrol E-RTTM uses measurements from the substations of a pipeline to calculate pressure residuals and monitor the pipeline for leaks. See also: Head Stations Monitoring, PipePatrol E-RTTM LDS, Sectional Monitoring.

– S (Continued) –

Sudden Leak: A sudden leak identifiable by a step signature, often the result of a pipeline rupture. PipePatrol E-RTTM raises leak alarm for sudden leaks of sufficient sizes. See also: Gradual Leak, Leak Alarm.

Supervisory Control and Data Acquisition (SCADA): The field information necessary for internal LDS usually will be provided by a Supervisory Control and Data Acquisition (SCADA) system; this is a computer-based data communication system that monitors, processes, transmits, and displays pipeline data for the pipeline controller. SCADA systems may be used directly for leak detection, they may provide support for an LDS, or an LDS may operate independently of SCADA. Generally, a pipeline LDS will use the data generated by a SCADA system. See also: Communication Protocol, Data Acquisition (DAQ), Data Communication Equipment (DCE), Digital Data Service (DDS), Master Station (MS), Measurement Station, Modbus, OLE For Process Control (OPC), Private Leased Line (PLL), Programmable Logic Controller (PLC), Public Switched Telephone Network (PSTN), and Remote Station (RS).

– T –

Thermodynamic Equation of State: Thermodynamic relation between pressure, temperature and density, which is true for a fluid. For crude oil, refined products and lubricating oils, corresponding relations and parameters are given by [API MPMS11]. Synonyms: EOS, PVT-Equation.

Time Tag: A SCADA feature recording the time that a measurement or event occurs along with the data. See also: Supervisory Control and Data Acquisition (SCADA).

Time-of-Flight Method: Leak location method where the difference in travel time of a sudden pressure drop propagating like a wave is detected at different locations along the pipeline. PipePatrol E-RTTM uses a model-based version, which is able to locate a leak even in transient conditions. See also: Gradient Intersection Method, Leak Localization.

Topology: Geometric arrangement of nodes and links that make up a network. Example: a ring, bus, or star configuration. See also: Supervisory Control and Data Acquisition (SCADA).

Transient State: State of a pipeline where physical values (e.g. flow and pressure) DO change significantly over time. [TRFL] requires an LDS to be capable of monitoring pipelines for leaks in transient conditions. See also: Steady State.

TRFL: „Technische Regeln für Rohrfernleitungsanlagen“ (Technical Rules for Pipelines). German regulation requiring LDSs for pipelines. Applies to most liquid and gas pipelines in Germany. See also: API RP 1130.

Turbine Meter: Flow-measuring device with a rotor that sense the velocity of flowing fluid in a closed conduit. Belongs to volumetric flow meters. See also: Coriolis Mass Meter, Flow meter, Orifice Plate, Positive Displacement Meter, Ultrasonic Meter, and Volumetric Flow meter.

– U –

Ultrasonic Meter: Flow-measuring device basing on the measurement of time delays of ultrasonic impulses. Belongs to volumetric Flow meters. See also: Coriolis Mass Meter, Flow meter, Orifice Plate, Positive Displacement Meter, Turbine Meter, and Volumetric Flow meter.

– U (Continued) –

Ultrasonic Meter: Flow-measuring device basing on the measurement of time delays of ultrasonic impulses. Belongs to volumetric Flow meters. See also: Coriolis Mass Meter, Flow meter, Orifice Plate, Positive Displacement Meter, Turbine Meter, and Volumetric Flow meter.

Uncompensated Mass Balance: Mass balance method without compensation for change of mass inventory in a pipeline. See also: Line Balance, Mass Balance, Compensated Mass Balance, and Volume Balance.

– V –

Virtual Flow: Unmeasured flow at substations bounded by two segments, calculated by the Pipeline Observers of these segments. See also: Pipeline Observer, Sectional Monitoring.

Virtual Pipeline: Synonym: Pipeline Observer.

Volume Balance: Special form of mass balance where density at inlet and outlet are equal so that volume imbalance summed up over a sufficient long time is ideally zero for leak-free pipelines. Another approach is to consider the imbalance for the leak-free pipeline and to use statistical methods to detect changes in the imbalance caused by a leak. See also: Line Balance, Mass Balance, Compensated Mass Balance, Uncompensated Mass Balance, and Volume Balance.

Volumetric Flow meter: Flow meter where flow is measured as volume flow. To determine mass flow the density of the fluids needs to be known; flow computer are normally used for this purpose. See also: Flowmeter, Flow Computer.

About the Author

Gerhard Geiger was born 1954 in Kaufbeuren, Germany, graduated from the University of Darmstadt in 1979, and was awarded a PhD in 1985 for his work on a new approach to technical diagnostics. He co-founded an engineering company active in the field of microelectronics and automation in 1987, and remained CEO until 1995. Here he was responsible for development, sales and marketing of pipeline leak detection systems, among other things. He was appointed to a professorship at the Westphalian University Gelsenkirchen (Germany) in 1995. Since then, the main focus of his work has been model-based pipeline leak detection methods. He has published more than 50 articles about leak detection, and developed the Extended Real-Time Transient Model (E-RTTM) technology.

In 1998, Professor Geiger and KROHNE Messtechnik in Duisburg started a close cooperation. Together, they developed KROHNE's very successful PipePatrol leak detection system family based on E-RTTM technology.